



User Manual
SKU: K000007_R4



Description

The Arduino® Starter Kit R4 is a hands-on learning platform built around the Arduino® UNO R4 WiFi. Featuring an Arm® Cortex®-M4 microcontroller, integrated Wi-Fi® and Bluetooth® via ESP32-S3, and a 12x8 red LED matrix, this kit provides makers, students, and educators with a reliable foundation to learn, prototype, and build interactive electronics projects. With included sensors, motors, and actuators, the Starter Kit R4 bridges theoretical learning and practical experimentation through engaging, hands-on activities that teach fundamental programming and electronics concepts.

Target Areas

Education, embedded programming, maker prototyping, STEM classrooms



CONTENTS

1 Application Examples	4
2 Starter Kit R4 Projects Book	5
2.1 Starter Kit R4 Online Projects	6
3 Features	7
3.1 Kit Contents	7
3.1.1 Main Board	7
3.1.2 Learning Materials	7
3.1.3 Cables & Power	7
3.1.4 Prototyping Tools	7
3.1.5 Input & Output Components	8
3.1.6 LEDs	8
3.1.7 Sensors	8
3.1.8 Actuators	8
3.1.9 Semiconductor Components	8
3.1.10 Passive Components	9
3.1.11 Accessories	9
3.1.12 Arduino UNO R4 WiFi (SKU: ABX00087)	10
4 Ratings	12
4.1 Recommended Operating Conditions	12
4.2 Pin Voltage and Current	12
5 Kit Power Supply	13
6 Device Operation	14
6.1 Getting Started - IDE	14
6.2 Getting Started - Arduino Cloud Editor	14
6.3 Getting Started - Arduino Cloud	14
6.4 Sample Sketches	14
6.5 Online Resources	14
7 Mechanical Information	15
7.1 Starter Kit R4 (K000007_R4) Dimensions	15
7.2 Starter Kit R4 Classroom Pack (K000007_R4-6P) Dimensions	15
7.3 UNO R4 WiFi (ABX00087) Dimensions	16
8 Product Compliance	17
9 FCC Caution	17



10 Declaration of Conformity CE DoC (EU)	18
11 Declaration of Conformity to EU RoHS & REACH 211 01/19/2021	
12 Conflict Minerals Declaration	19
13 Company Information	20
14 Reference Documentation	20
15 Document Revision History	20



1 Application Examples

The Starter Kit R4 offers a wide variety of practical applications, from classroom-friendly tutorials to interactive prototypes. Below are a few examples of what learners and developers can build with the kit:

- **Interactive Interfaces:** Create game controllers and HID devices that can interact with computers, exploring the bridge between physical and digital controls.
- **Educational Tools:** Teach students the fundamentals of electronics, embedded coding, and control logic using interactive guided experiments and hands-on projects.
- **LED Matrix Animations:** Use the onboard 12x8 red LED matrix to create visual displays, heartbeat monitors, status indicators, or animations for feedback and communication.
- **Temperature Sensing:** Build temperature-based monitoring systems using included thermistors to create chill-o-meters and responsive feedback devices.
- **Robotics & Motion:** Drive DC or servo motors to explore basic robotics and automated movement control applications like motorized pinwheels.
- **Sound & Music Projects:** Create musical instruments, synthesizers, and sound-responsive devices using piezo speakers, capacitive touch, and light sensors.
- **Sensor-Based Feedback Systems:** Develop touch-sensitive lamps, knock detectors, and mood indicators that respond to physical interactions and environmental changes.

2 Starter Kit R4 Projects Book

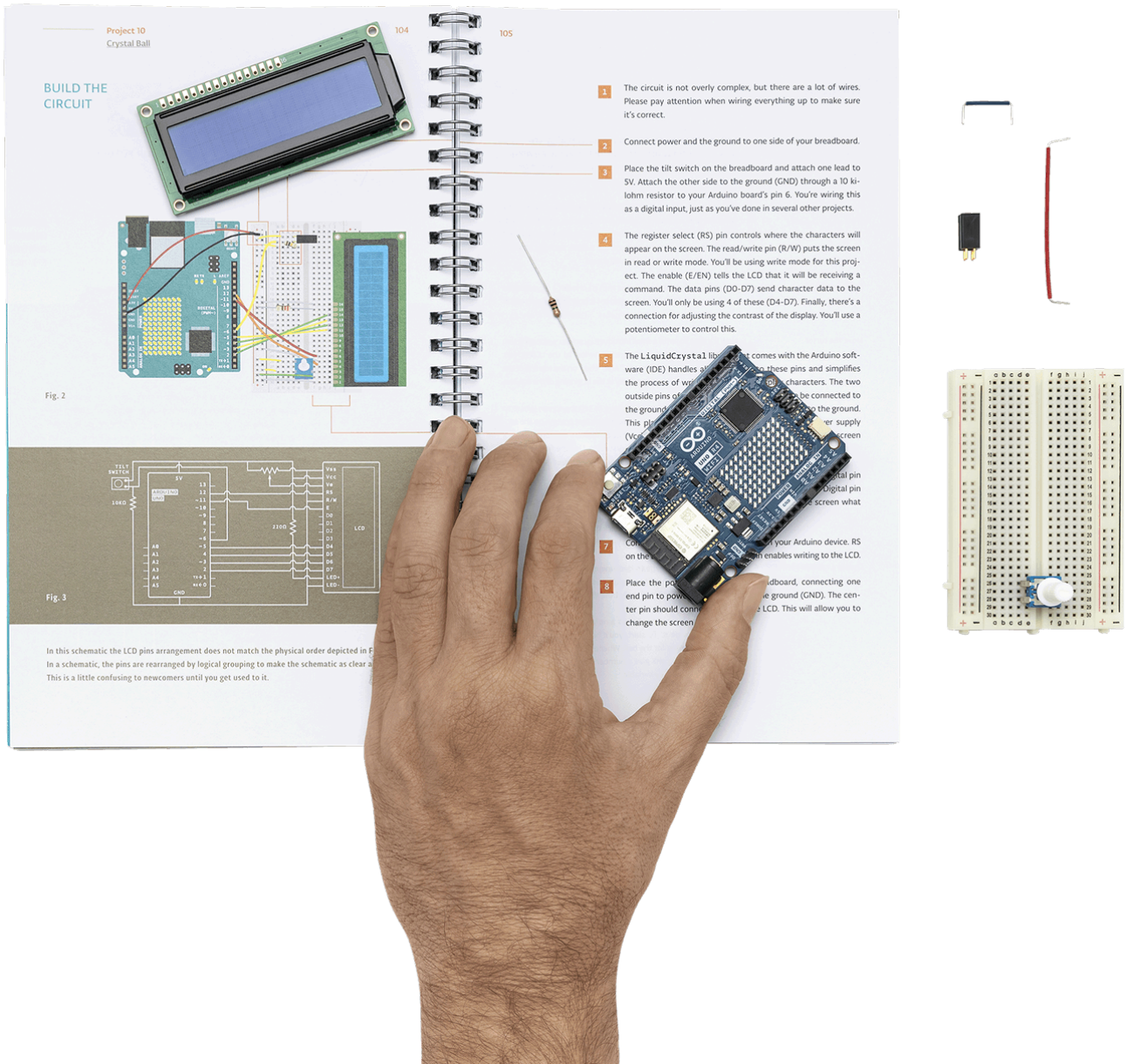

The Arduino Starter Kit R4 includes a printed book with 14 projects. Each project helps you learn how to use different components and write code with the Arduino UNO R4 WiFi. The projects start simple and become more advanced as you go.

No.	Project Title	What You Learn
00	Get Started	How to set up the software and board
01	Get to Know Your Tools	How to use a breadboard, resistors, and switches
02	Spaceship Interface	How to control LEDs with buttons
03	Chill-o-Meter	How to read temperature using a sensor

No.	Project Title	What You Learn
04	Color Mixing Lamp	How to use light sensors and fade LEDs
05	Mood Cue	How to give feedback using lights and sensors
06	Light Theremin	How to use light to make sound
07	Keyboard Instrument	How to play tones with a piezo speaker
08	Digital Hourglass	How to build a timer using LEDs
09	Motorized Pinwheel	How to control a motor
10	Crystal Ball	How to make random responses
11	Knock Lock	How to detect knocks with a piezo sensor
12	Touchy-feely Lamp	How to control light with a touch sensor
13	Hacking Buttons	How to reuse parts to make new controls

The book explains each step clearly and includes drawings and sample code. You can also visit the official project page at: arduino.cc/starterkit for updates and more projects.

Suggested additional materials are listed in the details of each project, such as basic crafting materials: paper, tape, markers, scissors and more. These are not included in the kit.

2.1 Starter Kit R4 Online Projects

The Starter Kit R4 includes a set of online projects. These projects build on the skills developed in the first 14 lessons, introducing topics such as computer interaction via USB (Human Interface Device - HID), capacitive touch, and enhanced use of the LED matrix. The first online module, **"Welcome Online"**, provides an introduction to the Arduino Cloud platform and how to use it with your kit.

The projects listed below represent the content available at the time of the kit's launch. Additional online projects will continue to be added over time to expand the learning experience and showcase new projects.

No.	Project Title	What You Learn
00-1	Welcome Online	Learn how to use the online Arduino Cloud platform.
00-2	Build a Project with Arduino AI Assistant	Learn how to build a project with the help of the Arduino AI assistant speaker.
14	HIDden Powers	Build a game controller that can interact with your computer, using HID and pushbuttons.
15	Heartbeat Monitor	Use the Love Button to pulse a heartbeat on the LED Matrix.
16	Funky Synth	Build a funky synth using capacitive touch and a piezo speaker.

You can follow the link below to access the official online course platform [11], where you will find the online projects with step-by-step instructions: courses.arduino.cc/starterkitr4. To access the course, users need an Arduino account.



3 Features

3.1 Kit Contents

The Starter Kit R4 includes the UNO R4 WiFi board and a wide selection of electronic components to build, test and explore interactive projects. All components are curated for step-by-step guided experimentation.

- **K000007_R4**: This is the SKU that represents the Starter Kit R4.
- **K000007_R4-6P**: This SKU represents the Starter Kit R4 Classroom pack, which contains Starter Kit R4 (x 6)

3.1.1 Main Board

- Arduino UNO R4 WiFi (SKU: ABX00087) (x1)

3.1.2 Learning Materials

- Project book - 150 pages (x1)

3.1.3 Cables & Power

- USB-C® cable (x1)
- 9V battery snap connector (x1)

3.1.4 Prototyping Tools

- Breadboard (x1)
- Easy-to-assemble base (x1)
- Solid core jumper wires (x70)
- Stranded jumper wires (x2)
- Male pin strip - 40x1 (x1)



3.1.5 Input & Output Components

- Pushbuttons (x6)
- LCD display - 16x2 characters (x1)
- Piezo capsule (x1)

3.1.6 LEDs

- Bright white LED (x1)
- RGB LED (x1)
- Red LEDs (x8)
- Green LEDs (x8)
- Yellow LEDs (x8)
- Blue LEDs (x3)

3.1.7 Sensors

- Phototransistors (x4)
- Temperature sensor (x1)
- Tilt sensor (x1)

3.1.8 Actuators

- Small DC motor 6/9 V (x1)
- Small servo motor (x1)

3.1.9 Semiconductor Components

- H-bridge motor driver (x1)
- Optocoupler (x2)
- MOSFET transistor (x1)
- Diodes (x3)

3.1.10 Passive Components

- Potentiometers (x3)
- Capacitors - 100 μF (x3)
- Resistors - 220 Ω (x11)
- Resistors - 560 Ω (x3)
- Resistors - 1 k Ω (x3)
- Resistors - 4.7 k Ω (x3)
- Resistors - 10 k Ω (x11)
- Resistors - 1 M Ω (x7)
- Resistors - 10 M Ω (x3)

3.1.11 Accessories

- Transparent color gels - red, green, blue (x3)

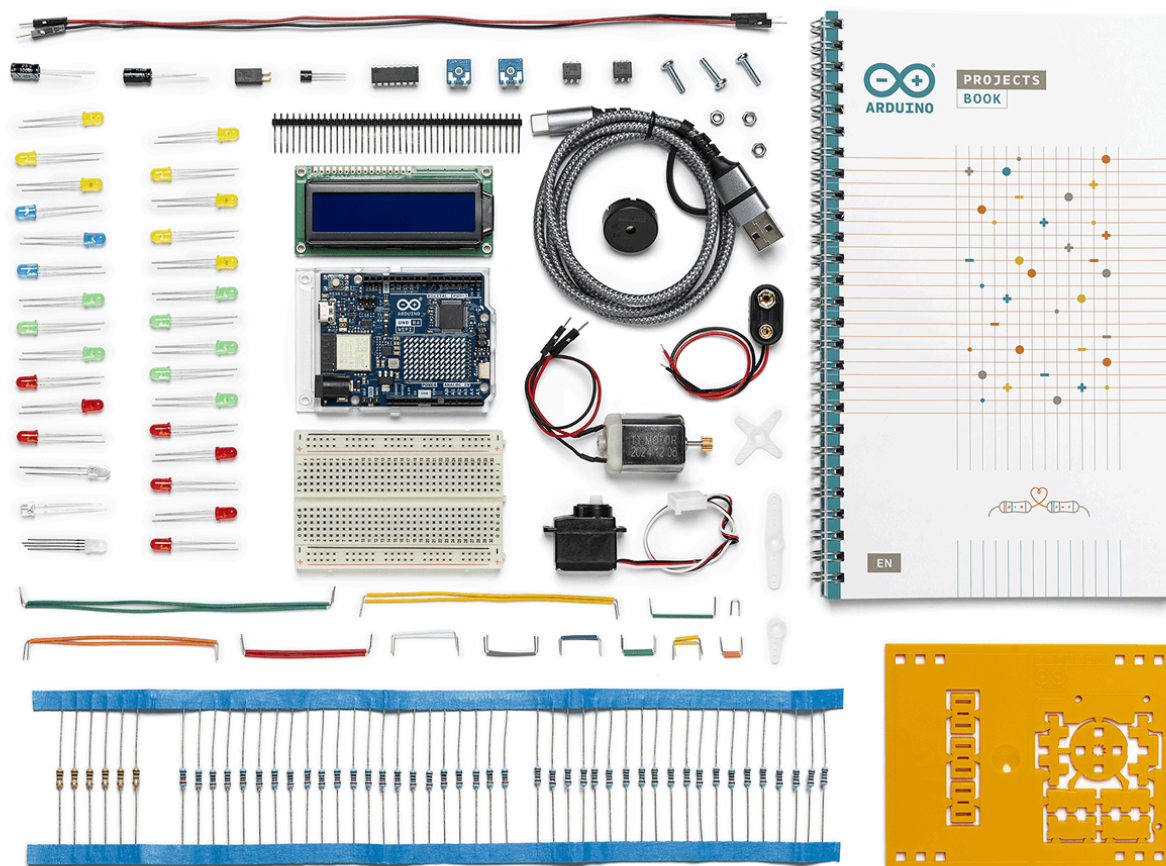

Exploded view of the Starter Kit R4 components

3.1.12 Arduino UNO R4 WiFi (SKU: ABX00087)

The UNO R4 WiFi is a modern 32-bit development board that combines the performance of the Renesas RA4M1 microcontroller with the wireless connectivity of the ESP32-S3-MINI-1 module. While preserving the classic UNO form factor and 5 V logic compatibility, it introduces new features including a built-in 12x8 LED matrix, CAN bus and QWIIC I2C connector. These additions make it suitable for both traditional prototyping and interactive electronics projects.

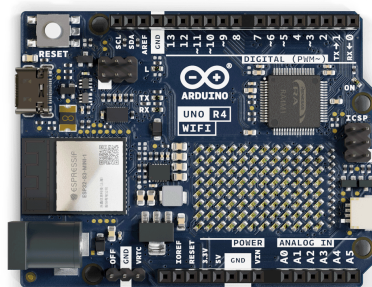

UNO R4 WiFi Board

Feature	Specification
Main MCU	Renesas RA4M1 (R7FA4M1AB3CFM#AA0)
Core	Arm® Cortex®-M4, 48 MHz with FPU
Memory	256 kB Flash, 32 kB SRAM, 8 kB EEPROM
Wireless MCU	ESP32-S3-MINI-1-N8
Wireless Connectivity	Wi-Fi® 4 (802.11 b/g/n), Bluetooth® 5 LE
Operating Voltage	5 V (RA4M1), 3.3 V (ESP32-S3)
USB Connector	USB-C
Power Input	VIN: 6-24 V / USB: 5 V
Digital I/O Pins	14
Analog Input Pins	6
PWM (Pulse Width Modulation) Outputs	6
DAC (Digital-to-Analog Converter)	1 × 12-bit (A0 pin)
LED Matrix	12x8 red matrix, programmable
Communication Interfaces	UART (1), I2C (2), SPI (1), CAN (1)
Special Interfaces	QWIIC connector (3.3 V I2C), ESP header
Additional Features	RTC, OPAMP, DMA controller, CTSU
Dimensions	68.58 mm × 53.34 mm

By default, programming the RA4M1 microcontroller is handled through the ESP32-S3, which works as a USB bridge. This configuration allows uploading via USB-C without requiring additional setup.

The board features a USB-C port for both powering and programming. It also supports serial communication and works as the main development interface.

Warning: Do not exceed 5 V on the USB-C port to avoid hardware damage.

The RA4M1 microcontroller provides a 12-bit DAC connected to the A0 pin. It can generate analog output signals such as variable voltage levels or waveforms for audio and signal testing applications.

The onboard QWIIC connector (SM04B-SRSS-TB) allows plug-and-play I2C communication with 3.3 V QWIIC-compatible modules. It is connected to a secondary I2C bus powered by the onboard 3.3 V regulator.

The main I2C bus is also accessible on A4 (SDA) and A5 (SCL) pins. Avoid using A4/A5 as analog inputs while I2C communication is active.

For more technical information, schematics, and configuration details, refer to the official UNO R4 WiFi documentation: [UNO R4 WiFi Official Documentation \[1\]](#)

4 Ratings

4.1 Recommended Operating Conditions

The recommended electrical and thermal operating ranges for the Arduino UNO R4 WiFi board are as follows:

Symbol	Description	Minimum	Typical	Maximum	Unit
V_{IN}	Input voltage from VIN pad / DC Jack	6	7.0	24	V
V_{USB}	Input voltage from USB connector	4.8	5.0	5.5	V
T_{OP}	Operating Temperature	-40	25	85	°C

Note: Operating conditions reflect general limits for the main board and consider reasonable usage of connected peripherals. Component-specific ratings may vary.

The UNO R4 WiFi supports power inputs via USB-C or the VIN pin (DC barrel jack). A buck converter (ISL854102FRZ) regulates VIN input (6-24 V) down to 5 V. USB input is internally dropped to ~4.7 V due to a Schottky diode.

A 3.3 V linear regulator (SGM2205-3.3XKC3G/TR) supplies the ESP32-S3 and other 3.3 V peripherals.

4.2 Pin Voltage and Current

- **Logic Levels:** RA4M1 operates at 5 V / ESP32-S3 at 3.3 V
- **Current per GPIO:** Up to 8 mA
- **Important:** Do not apply 5 V signals to ESP32-S3 pins

Always use external power supplies for high-current loads like servos or DC motors.

For more technical information, schematics, and configuration details, refer to the official UNO R4 WiFi documentation: [UNO R4 WiFi Official Documentation \[1\]](#)

5 Kit Power Supply

The Starter Kit R4 supports multiple powering options via the Arduino UNO R4 WiFi board. When connecting additional peripherals, ensure they are within the supported voltage and current limits.

- **VIN / Barrel Jack:** Accepts 6-24 VDC input, regulated to 5 V using the onboard buck converter (ISL854102FRZ). Recommended for projects requiring higher or isolated input voltage sources.

Note: A 9 V battery snap connector is included in the kit for use with a 9 V battery as a power source if desired. The 9 V battery is not included and must be purchased separately.

- **USB-C Connector:** Provides 5 V directly from the USB host. Actual voltage seen by the board is slightly reduced due to a Schottky diode (~4.7 V). Suitable for desktop or classroom use.
- **5 V Pin:** Provides regulated 5 V output when the board is powered via USB or VIN. Use with caution and avoid connecting high-current loads (e.g., motors) directly to this pin.

Warning: Exceeding the voltage or current ratings of the board or connected components may result in damage or unsafe operation. Always check the specifications of peripherals before connecting them.

For more technical information, schematics, and configuration details, refer to the official UNO R4 WiFi documentation: [UNO R4 WiFi Official Documentation \[1\]](#)

6 Device Operation

6.1 Getting Started - IDE

If you want to program your Arduino Starter Kit R4 offline, install the Arduino Desktop IDE [2]. To connect the Arduino UNO R4 WiFi to your computer, you will need a USB-C cable.

6.2 Getting Started - Arduino Cloud Editor

All components of the Arduino Starter Kit R4 work seamlessly on the Arduino Cloud Editor [3] by installing a simple plugin. The Arduino Cloud Editor is hosted online, ensuring it is always up-to-date with the latest features and support for all boards and devices. Follow the Getting Started guide [6] to start coding in the browser and upload your sketches onto the Arduino UNO R4 WiFi.

6.3 Getting Started - Arduino Cloud

The Arduino Starter Kit R4 is fully compatible with the Arduino Cloud, allowing you to explore online development tools and AI-assisted project building using the UNO R4 WiFi board. The kit includes guided tutorials for getting started with the Arduino Cloud platform and leveraging the Arduino AI Assistant for project development. To learn how to integrate your projects with the Cloud, refer to the official documentation [6].

6.4 Sample Sketches

Sample sketches for the Starter Kit R4 can be found either in the "Examples" menu in the Arduino IDE or the LED Matrix tutorial section of Arduino documentation [7]. These examples include basic and advanced applications showcasing motion and environmental monitoring capabilities.

6.5 Online Resources

Now that you have gone through the basics of what you can do with the Starter Kit R4, you can explore the endless possibilities it provides by checking exciting projects on Arduino Project Hub [5], the Arduino Library Reference [9], and the online Starter Kit R4 product page [10].



7 Mechanical Information

7.1 Starter Kit R4 (K000007_R4) Dimensions

View	Measurement
Width	245 mm
Length	160 mm
Height	41 mm
Weight	0.864 Kg

7.2 Starter Kit R4 Classroom Pack (K000007_R4-6P) Dimensions

View	Measurement
Width	245 mm
Length	160 mm
Height	146 mm
Weight	5.4 kg

7.3 UNO R4 WiFi (ABX00087) Dimensions

View	Measurement
Width	68.58 mm
Length	53.34 mm

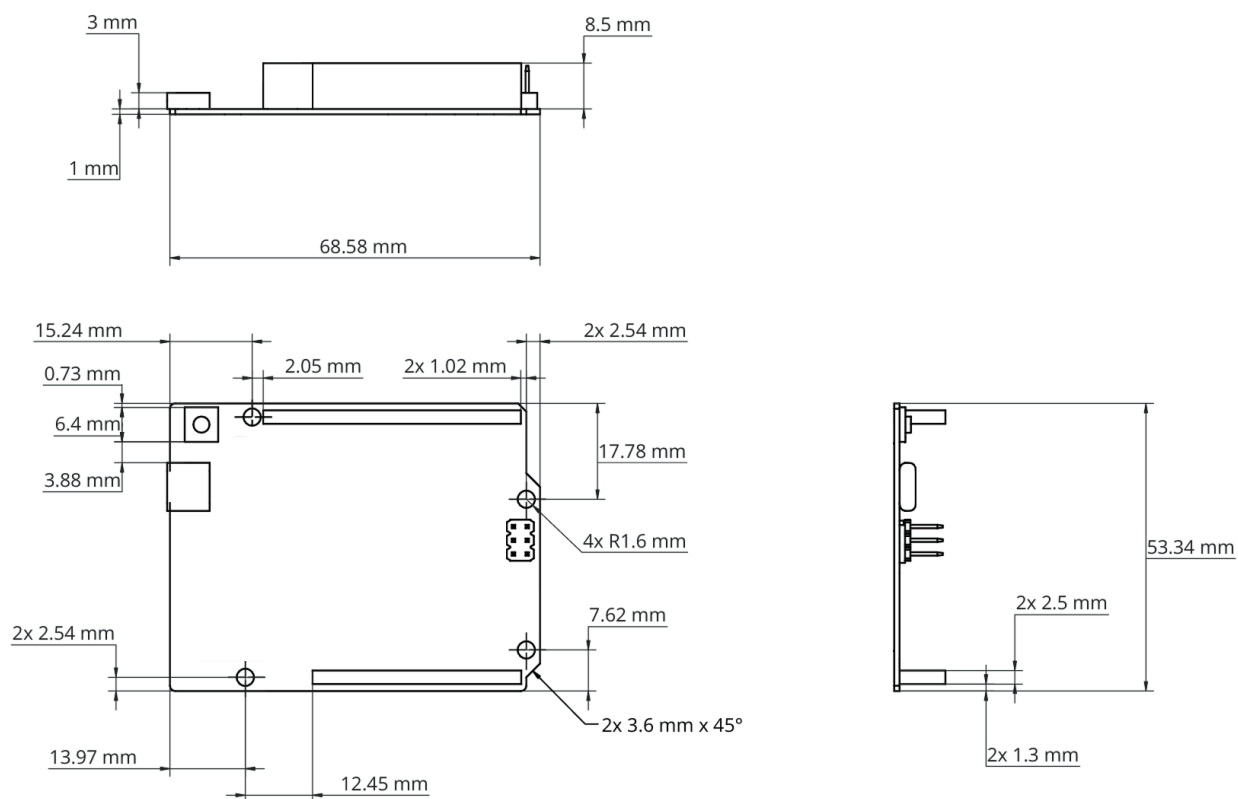

Board Dimensions

8 Product Compliance

The Arduino Starter Kit R4 is composed of multiple individual components, with the UNO R4 WiFi being the main board, it complies with specific regulations and certifications. For detailed product compliance information, please refer to the corresponding datasheets of each component included in the kit:

- UNO R4 WiFi Compliance Information [1]

9 FCC Caution

The UNO R4 WiFi of the Arduino Starter Kit R4 is subject to individual FCC regulations. Please refer to the FCC documentation linked in each Arduino component's datasheet for specific compliance details:

- UNO R4 WiFi Compliance Information [1]

Any Changes or modifications not expressly approved by the party responsible for compliance could void the user's authority to operate the equipment.

This device complies with part 15 of the FCC Rules. Operation is subject to the following two conditions:

(1) This device may not cause harmful interference

(2) this device must accept any interference received, including interference that may cause undesired operation.

FCC RF Radiation Exposure Statement:

1. This Transmitter must not be co-located or operating in conjunction with any other antenna or transmitter.
2. This equipment complies with RF radiation exposure limits set forth for an uncontrolled environment.
3. This equipment should be installed and operated with a minimum distance of 20 cm between the radiator & your body.

Note: This equipment has been tested and found to comply with the limits for a Class B digital device, pursuant to part 15 of the FCC Rules. These limits are designed to provide reasonable protection against harmful interference in a residential installation. This equipment generates, uses and can radiate radio frequency energy and, if not installed and used in accordance with the instructions, may cause harmful interference to radio communications. However, there is no guarantee that interference will not occur in a particular installation. If this equipment does cause harmful interference to radio or television reception, which can be determined by turning the equipment off and on, the user is encouraged to try to correct the interference by one or more of the following measures:

- Reorient or relocate the receiving antenna.
- Increase the separation between the equipment and receiver.
- Connect the equipment into an outlet on a circuit different from that to which the receiver is connected.
- Consult the dealer or an experienced radio/TV technician for help.

English: User manuals for licence-exempt radio apparatus shall contain the following or equivalent notice in a conspicuous location in the user manual or alternatively on the device or both. This device complies with Industry Canada licence-exempt RSS standard(s). Operation is subject to the following two conditions:

(1) this device may not cause interference

(2) this device must accept any interference, including interference that may cause undesired operation of the device.

French: Le présent appareil est conforme aux CNR d'Industrie Canada applicables aux appareils radio exempts de licence. L'exploitation est autorisée aux deux conditions suivantes :

(1) l' appareil n' doit pas produire de brouillage

(2) l'utilisateur de l'appareil doit accepter tout brouillage radioélectrique subi, même si le brouillage est susceptible d'en compromettre le fonctionnement.

IC SAR Warning:

English This equipment should be installed and operated with a minimum distance of 20 cm between the radiator and your body.

French: Lors de l' installation et de l' exploitation de ce dispositif, la distance entre le radiateur et le corps est d' au moins 20 cm.

10 Declaration of Conformity CE DoC (EU)

We declare under our sole responsibility that the products above are in conformity with the essential requirements of the following EU Directives and therefore qualify for free movement within markets comprising the European Union (EU) and European Economic Area (EEA).

11 Declaration of Conformity to EU RoHS & REACH 211 01/19/2021

Arduino boards are in compliance with RoHS 2 Directive 2011/65/EU of the European Parliament and RoHS 3 Directive 2015/863/EU of the Council of 4 June 2015 on the restriction of the use of certain hazardous substances in electrical and electronic equipment.

Substance	Maximum Limit (ppm)
Lead (Pb)	1000
Cadmium (Cd)	100
Mercury (Hg)	1000
Hexavalent Chromium (Cr6+)	1000
Poly Brominated Biphenyls (PBB)	1000
Poly Brominated Diphenyl ethers (PBDE)	1000
Bis(2-Ethylhexyl) phthalate (DEHP)	1000
Benzyl butyl phthalate (BBP)	1000
Dibutyl phthalate (DBP)	1000
Diisobutyl phthalate (DIBP)	1000

Exemptions : No exemptions are claimed.



Arduino Boards are fully compliant with the related requirements of European Union Regulation (EC) 1907 /2006 concerning the Registration, Evaluation, Authorization and Restriction of Chemicals (REACH). We declare none of the SVHCs (<https://echa.europa.eu/web/guest/candidate-list-table>), the Candidate List of Substances of Very High Concern for authorization currently released by ECHA, is present in all products (and also package) in quantities totaling in a concentration equal or above 0.1%. To the best of our knowledge, we also declare that our products do not contain any of the substances listed on the "Authorization List" (Annex XIV of the REACH regulations) and Substances of Very High Concern (SVHC) in any significant amounts as specified by the Annex XVII of Candidate list published by ECHA (European Chemical Agency) 1907 /2006/EC.

12 Conflict Minerals Declaration

As a global supplier of electronic and electrical components, Arduino is aware of our obligations with regards to laws and regulations regarding Conflict Minerals, specifically the Dodd-Frank Wall Street Reform and Consumer Protection Act, Section 1502. Arduino does not directly source or process conflict minerals such as Tin, Tantalum, Tungsten, or Gold. Conflict minerals are contained in our products in the form of solder, or as a component in metal alloys. As part of our reasonable due diligence Arduino has contacted component suppliers within our supply chain to verify their continued compliance with the regulations. Based on the information received thus far we declare that our products contain Conflict Minerals sourced from conflict-free areas.



13 Company Information

Company name	Arduino S.r.l.
Address	Via Andrea Appiani, 25 – 20900 Monza (Italy)

14 Reference Documentation

No.	Reference	Link
1	UNO R4 WiFi Documentation	https://docs.arduino.cc/hardware/uno-r4-wifi/
2	Arduino IDE	https://www.arduino.cc/en/software
3	Arduino Cloud Editor	https://create.arduino.cc/editor
4	Language Reference	https://www.arduino.cc/reference/en/
5	Project Hub	https://create.arduino.cc/projecthub
6	Cloud Getting Started Guide	https://docs.arduino.cc/cloud/web-editor/tutorials/getting-started
7	LED Matrix Examples	https://docs.arduino.cc/tutorials/uno-r4-wifi/led-matrix
8	Wi-Fi Examples	https://docs.arduino.cc/tutorials/uno-r4-wifi/wifi-examples
9	Library Reference	https://github.com/arduino-libraries/
10	Online Store	https://store.arduino.cc/products/starter-kit-r4
11	Online Starter Kit R4 Course	https://courses.arduino.cc/starterkitr4

15 Document Revision History

Date	Revision	Changes
18/11/2025	1	First release