

LF353 Wide-Bandwidth JFET-Input Dual Operational Amplifier

1 Features

- Low Input Bias Current 50 pA Typical
- Low Input Noise Current 0.01 pA/√Hz Typical
- Low Supply Current 3.6 mA Typical
- High Input Impedance $10^{12} \Omega$ Typical
- Internally-Trimmed Offset Voltage
- Gain Bandwidth 3 MHz Typical
- High Slew Rate 13 V/μs Typical

2 Applications

- Motor Integrated Systems: UPS
- Drives and Control Solutions: AC Inverter and VF Drives
- Renewables: Solar Inverters
- Pro Audio Mixers
- Oscilloscopes

3 Description

This LF353 device is a low-cost, high-speed, JFET-input operational amplifier with very low input offset voltage. It requires low supply current yet maintains a large gain-bandwidth product and a fast slew rate. In addition, the matched high-voltage JFET input provides very low input bias and offset currents.

The LF353 can be used in applications such as high-speed integrators, digital-to-analog converters, sample-and-hold circuits, and many other circuits.

The LF353 is characterized for operation from 0°C to 70°C.

Device Information⁽¹⁾

| PART NUMBER | PACKAGE | BODY SIZE (NOM) |
|-------------|----------|-------------------|
| LF353D | SOIC (8) | 4.90 mm × 3.91 mm |
| LF353P | PDIP (8) | 9.81 mm × 6.35 mm |

(1) For all available packages, see the orderable addendum at the end of the data sheet.

Symbol

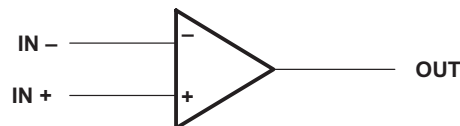

Table of Contents

| | |
|---|--|
| 1 Features 1 2 Applications 1 3 Description 1 4 Revision History 2 5 Pin Configuration and Functions 3 6 Specifications 4 6.1 Absolute Maximum Ratings 4 6.2 ESD Ratings..... 4 6.3 Recommended Operating Conditions 4 6.4 Thermal Information 4 6.5 Electrical Characteristics..... 5 6.6 Switching Characteristics 5 6.7 Typical Characteristics 6 7 Parameter Measurement Information 7 8 Detailed Description 8 8.1 Overview 8 8.2 Functional Block Diagram 8 | 8.3 Feature Description..... 8 8.4 Device Functional Modes..... 8 9 Application and Implementation 9 9.1 Application Information..... 9 9.2 Typical Application 9 10 Power Supply Recommendations 10 11 Layout 11 11.1 Layout Guidelines 11 11.2 Layout Example 11 12 Device and Documentation Support 12 12.1 Documentation Support 12 12.2 Community Resources..... 12 12.3 Trademarks 12 12.4 Electrostatic Discharge Caution..... 12 12.5 Glossary 12 13 Mechanical, Packaging, and Orderable Information 12 |
|---|--|

4 Revision History

NOTE: Page numbers for previous revisions may differ from page numbers in the current version.

| Changes from Revision B (August 1994) to Revision C | Page |
|---|------|
| <ul style="list-style-type: none"> • Added <i>ESD Ratings</i> table, <i>Feature Description</i> section, <i>Device Functional Modes</i>, <i>Application and Implementation</i> section, <i>Power Supply Recommendations</i> section, <i>Layout</i> section, <i>Device and Documentation Support</i> section, and <i>Mechanical, Packaging, and Orderable Information</i> section. | 1 |

5 Pin Configuration and Functions

**D or P Package
8-Pin SOIC or PDIP
Top View**

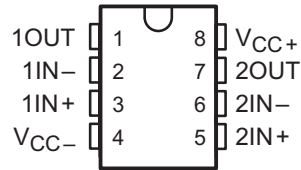

Pin Functions

| PIN | | I/O | DESCRIPTION |
|------------------|-----|-----|-------------------------|
| NAME | NO. | | |
| 1OUT | 1 | O | Output |
| 1IN- | 2 | I | Inverting input |
| 1IN+ | 3 | I | Noninverting input |
| V _{CC-} | 4 | — | Negative supply voltage |
| 2IN+ | 5 | I | Noninverting input |
| 2IN- | 6 | I | Inverting input |
| 2OUT | 7 | O | Output |
| V _{CC+} | 8 | — | Positive supply voltage |

6 Specifications

6.1 Absolute Maximum Ratings

 over operating free-air temperature range (unless otherwise noted)⁽¹⁾

| | | MIN | MAX | UNIT |
|------------------|--|-----|-----------|------|
| V _{CC+} | Supply voltage | | 18 | V |
| V _{CC-} | Supply voltage | | -18 | V |
| VID | Differential input voltage | | ±30 | V |
| VI | Input voltage ⁽²⁾ | | ±15 | V |
| | Duration of output short circuit | | Unlimited | s |
| | Continuous total power dissipation | | 500 | mW |
| | Lead temperature 1.6 mm (1/16 inch) from case for 10 s | | 260 | °C |
| T _J | Junction temperature | | 150 | °C |
| T _{stg} | Storage temperature | -65 | 150 | °C |

- (1) Stresses beyond those listed under *Absolute Maximum Ratings* may cause permanent damage to the device. These are stress ratings only, which do not imply functional operation of the device at these or any other conditions beyond those indicated under *Recommended Operating Conditions*. Exposure to absolute-maximum-rated conditions for extended periods may affect device reliability.
- (2) Unless otherwise specified, the absolute maximum negative input voltage is equal to the negative power supply voltage.

6.2 ESD Ratings

| | | | VALUE | UNIT |
|--------------------|-------------------------|--|-------|------|
| V _(ESD) | Electrostatic discharge | Human-body model (HBM), per ANSI/ESDA/JEDEC JS-001 ⁽¹⁾ | ±2000 | V |
| | | Charged-device model (CDM), per JEDEC specification JESD22-C101 ⁽²⁾ | ±1000 | |

- (1) JEDEC document JEP155 states that 500-V HBM allows safe manufacturing with a standard ESD control process.
- (2) JEDEC document JEP157 states that 250-V CDM allows safe manufacturing with a standard ESD control process.

6.3 Recommended Operating Conditions

over operating free-air temperature range (unless otherwise noted)

| | | MIN | MAX | UNIT |
|------------------|-----------------------|----------------------|----------------------|------|
| V _{CC+} | Supply voltage | 3.5 | 18 | V |
| V _{CC-} | Supply voltage | -3.5 | -18 | V |
| V _{CM} | Common-mode voltage | V _{CC-} + 4 | V _{CC+} - 4 | V |
| T _A | Operating temperature | 0 | 70 | °C |

6.4 Thermal Information

| THERMAL METRIC ⁽¹⁾ | LF353 | | UNIT | |
|-------------------------------|--|----------|------|------|
| | D (SOIC) | P (PDIP) | | |
| | 8 PINS | 8 PINS | | |
| R _{θJA} | Junction-to-ambient thermal resistance | 106.6 | 55.1 | °C/W |
| R _{θJC(top)} | Junction-to-case (top) thermal resistance | 51.5 | 45 | °C/W |
| R _{θJB} | Junction-to-board thermal resistance | 46.5 | 32.2 | °C/W |
| ψ _{JT} | Junction-to-top characterization parameter | 9.8 | 22.6 | °C/W |
| ψ _{JB} | Junction-to-board characterization parameter | 46.1 | 32.2 | °C/W |

- (1) For more information about traditional and new thermal metrics, see the *Semiconductor and IC Package Thermal Metrics* application report, [SPRA953](#).

6.5 Electrical Characteristics

 $T_A = 0^\circ\text{C}$ to 70°C , $V_{CC\pm} = \pm 15\text{ V}$ (unless otherwise noted)

| PARAMETER | | TEST CONDITIONS | | MIN | TYP | MAX | UNIT |
|----------------|--|--|---------------------------|----------|------------|-----|------------------------------|
| V_{IO} | Input offset voltage | $V_{IC} = 0$, $R_S = 10\text{ k}\Omega$ | $T_A = 25^\circ\text{C}$ | | 5 | 10 | mV |
| | | | Full range ⁽¹⁾ | | | 13 | |
| α_{VIO} | Average temperature coefficient of inputs offset voltage | $V_{IC} = 0$, $R_S = 10\text{ k}\Omega$ | | | 10 | | $\mu\text{V}/^\circ\text{C}$ |
| I_{IO} | Input offset current ⁽²⁾ | $V_{IC} = 0$ | $T_A = 25^\circ\text{C}$ | | 25 | 100 | pA |
| | | | $T_A = 70^\circ\text{C}$ | | | 4 | nA |
| I_{IB} | Input bias current ⁽²⁾ | $V_{IC} = 0$ | $T_A = 25^\circ\text{C}$ | | 50 | 200 | pA |
| | | | $T_A = 70^\circ\text{C}$ | | | 8 | nA |
| V_{ICR} | Common-mode input voltage range | Lower limit of range | | -11 | -12 | | V |
| | | Upper limit of range | | 11 | 15 | | |
| V_{OM} | Maximum peak output voltage swing | $R_L = 10\text{ k}\Omega$ | | ± 12 | ± 13.5 | | V |
| A_{VD} | Large-signal differential voltage | $V_O = \pm 10\text{ V}$, $R_L = 2\text{ k}\Omega$ | $T_A = 25^\circ\text{C}$ | | 25 | 100 | V/mV |
| | | | Full range ⁽¹⁾ | | 15 | | |
| r_i | Input resistance | $T_J = 25^\circ\text{C}$ | | | 10^{12} | | Ω |
| CMRR | Common-mode rejection ratio | $R_S \leq 10\text{ k}\Omega$ | | 70 | 100 | | dB |
| k_{SVR} | Supply-voltage rejection ratio | See ⁽³⁾ | | 70 | 100 | | dB |
| I_{CC} | Supply current | | | | 3.6 | 6.5 | mA |

(1) Full range is 0°C to 70°C

(2) Input bias currents of a FET-input operational amplifier are normal junction reverse currents, which are temperature sensitive. Pulse techniques must be used that will maintain the junction temperatures as close to the ambient temperature as possible.

(3) Supply-voltage rejection ratio is measured for both supply magnitudes increasing or decreasing simultaneously.

6.6 Switching Characteristics

 $V_{CC\pm} = \pm 15\text{ V}$, $T_A = 25^\circ\text{C}$, over operating free-air temperature range (unless otherwise noted)

| PARAMETER | | TEST CONDITIONS | | MIN | TYP | MAX | UNIT |
|-----------------|--------------------------------|---|--|-----|------|-----|------------------------------|
| V_{O1}/V_{O2} | Crosstalk attenuation | $f = 1\text{ kHz}$ | | | 120 | | dB |
| SR | Slew rate | | | 8 | 13 | | $\text{V}/\mu\text{s}$ |
| B1 | Unity-gain bandwidth | | | | 3 | | MHz |
| V_n | Equivalent input noise voltage | $f = 1\text{ kHz}$, $R_S = 20\ \Omega$ | | | 18 | | $\text{nV}/\sqrt{\text{Hz}}$ |
| I_n | Equivalent input noise current | $f = 1\text{ kHz}$ | | | 0.01 | | $\text{pA}/\sqrt{\text{Hz}}$ |

6.7 Typical Characteristics

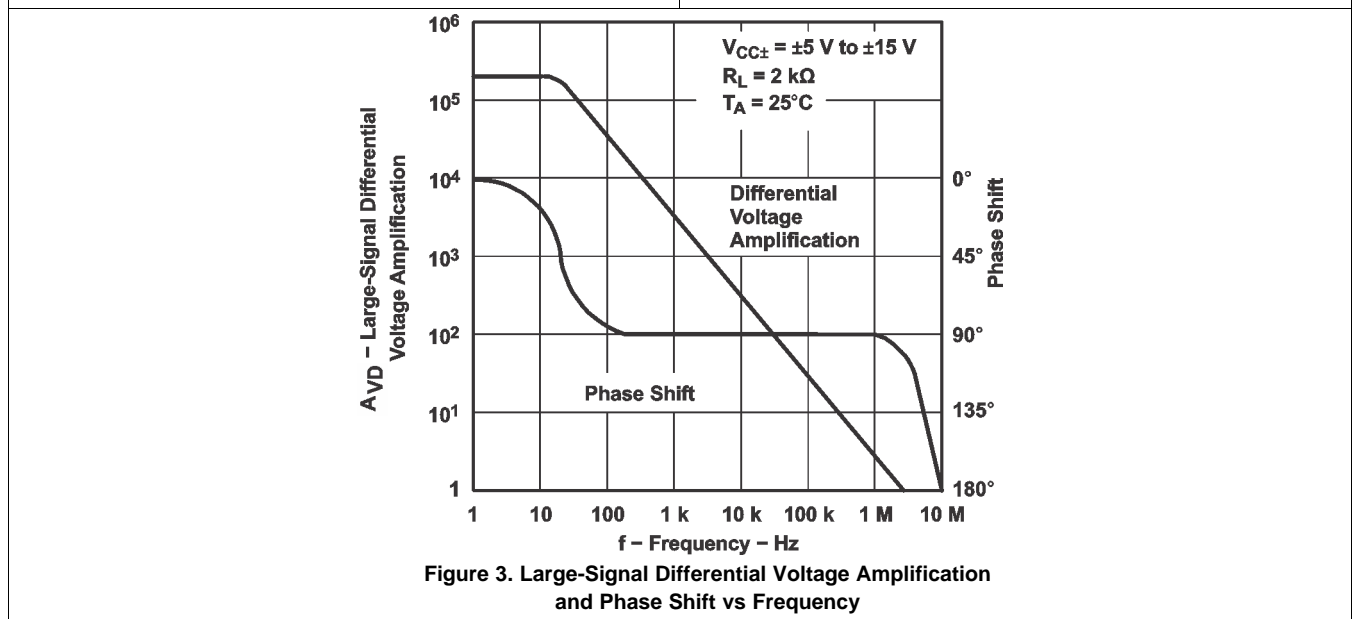
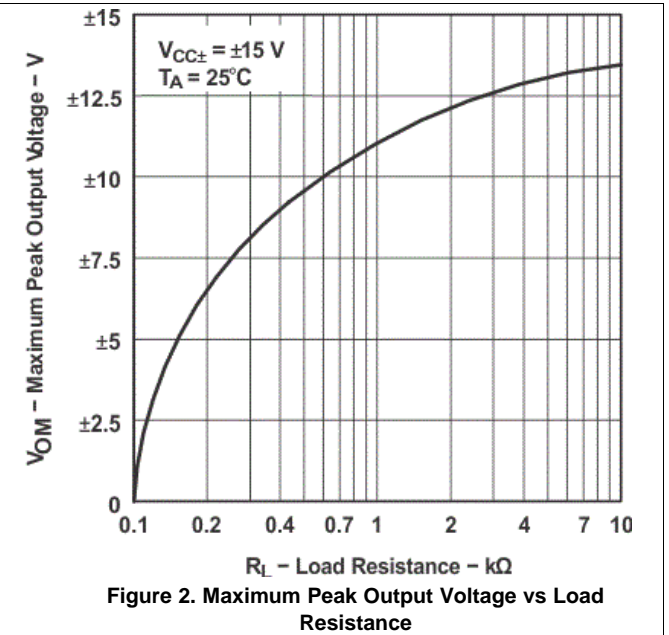
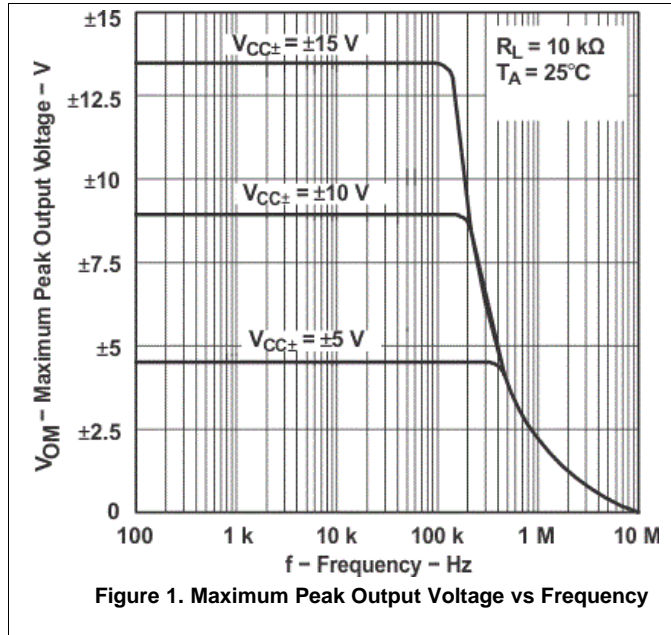

7 Parameter Measurement Information

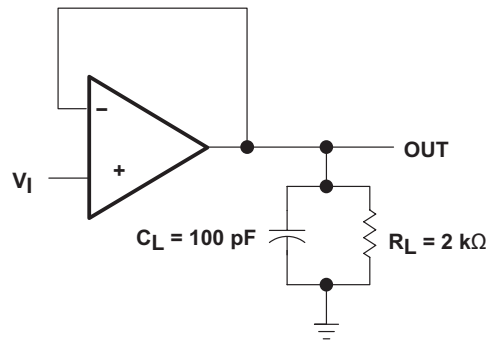

Figure 4. Unity-Gain Amplifier

8 Detailed Description

8.1 Overview

The LF353 device is a JFET-input operational amplifier with low input bias and offset currents and fast slew rate. Each amplifier features JFET inputs (for high input impedance) coupled with bipolar output stages integrated on a single monolithic chip. The output is protected against shorts due to the resistive 200-Ω output impedance.

8.2 Functional Block Diagram

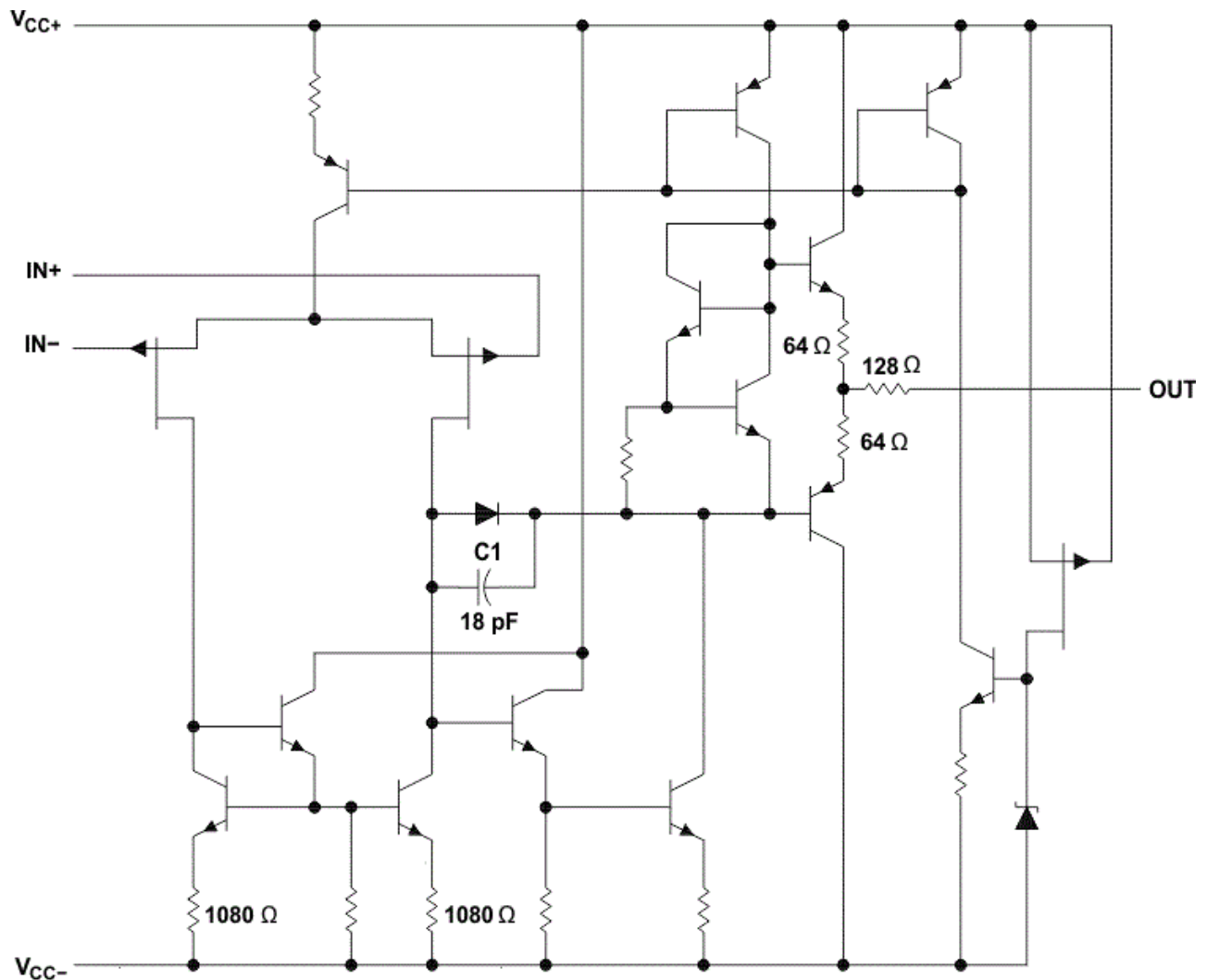

8.3 Feature Description

8.3.1 Slew Rate

The slew rate is the rate at which an operational amplifier can change its output when there is a change on the input. These devices have a 13-V/μs slew rate.

8.4 Device Functional Modes

These devices are powered on when the supply is connected. This device can be operated as a single-supply operational amplifier or dual-supply amplifier depending on the application.

9 Application and Implementation

NOTE

Information in the following applications sections is not part of the TI component specification, and TI does not warrant its accuracy or completeness. TI's customers are responsible for determining suitability of components for their purposes. Customers should validate and test their design implementation to confirm system functionality.

9.1 Application Information

The LF353 has two independent amplifiers that have very low input bias current which allow using higher resistance resistors in the feedback network. The upper input common mode range goes to the upper supply rail. The lower common mode range does not include the negative supply rail. Output resistance is 200 ohms to protect the device from accidental shorts.

9.2 Typical Application

A typical application for an operational amplifier is an inverting amplifier. This amplifier takes a positive voltage on the input, and makes it a negative voltage. In the same manner, it also makes negative voltages positive.

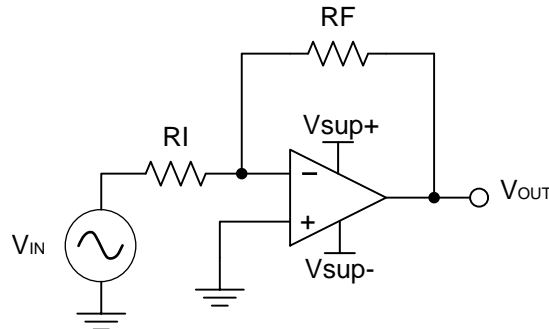

Figure 5. Inverting Amplifier

9.2.1 Design Requirements

The supply voltage must be chosen such that it is larger than the input voltage range and output range. For instance, this application scales a signal of ± 0.5 V to ± 1.8 V. Setting the supply at ± 12 V is sufficient to accommodate this application.

9.2.2 Detailed Design Procedure

Determine the gain required by the inverting amplifier using [Equation 1](#) and [Equation 2](#).

$$A_v = \frac{V_{OUT}}{V_{IN}} \quad (1)$$

$$A_v = \frac{1.8}{-0.5} = -3.6 \quad (2)$$

Once the desired gain is determined, choose a value for R_I or R_F . Choosing a value in the k Ω range is desirable because the amplifier circuit uses currents in the mA range. This ensures the part does not draw too much current. For this example, choose 10 k Ω for R_I and 36 k Ω for R_F , as shown in [Equation 3](#).

$$A_v = -\frac{R_F}{R_I} \quad (3)$$

Typical Application (continued)

9.2.3 Application Curve

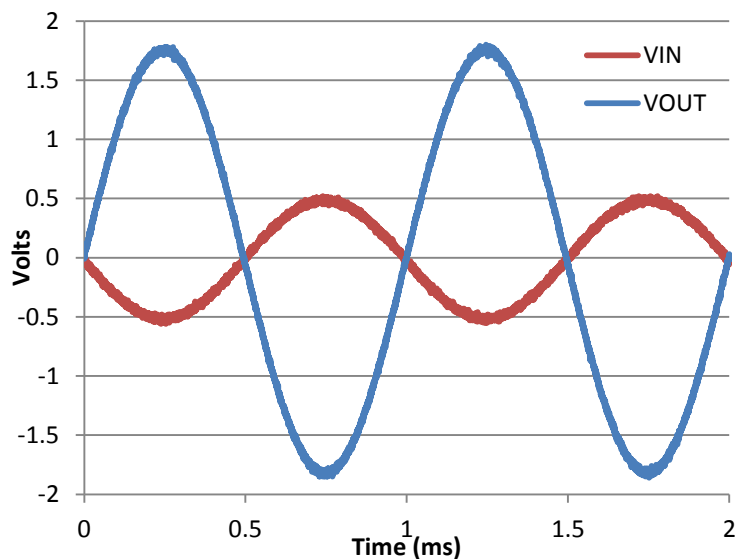

Figure 6. Input and Output Voltages of the Inverting Amplifier

10 Power Supply Recommendations

CAUTION

Supply voltages larger than 36 V for a single-supply or outside the range of ± 18 V for a dual-supply can permanently damage the device (see the [Absolute Maximum Ratings](#)).

Place 0.1- μ F bypass capacitors close to the power-supply pins to reduce errors coupling in from noisy or high-impedance power supplies. For more detailed information on bypass capacitor placement, see the [Layout Example](#).

11 Layout

11.1 Layout Guidelines

For best operational performance of the device, use the following layout guidelines:

- Noise can propagate into analog circuitry through the power pins of the circuit as a whole, as well as the operational amplifier. Bypass capacitors are used to reduce the coupled noise by providing low impedance power sources local to the analog circuitry.
 - Connect low-ESR, 0.1- μ F ceramic bypass capacitors between each supply pin and ground, placed as close to the device as possible. A single bypass capacitor from V+ to ground is applicable for single supply applications.
- Separate grounding for analog and digital portions of circuitry is one of the simplest and most-effective methods of noise suppression. One or more layers on multilayer PCBs are usually devoted to ground planes. A ground plane helps distribute heat and reduces EMI noise pickup. Make sure to physically separate digital and analog grounds, paying attention to the flow of the ground current. For more detailed information, see *Circuit Board Layout Techniques* (SLOA089).
- To reduce parasitic coupling, run the input traces as far away from the supply or output traces as possible. If it is not possible to keep them separate, it is much better to cross the sensitive trace perpendicular as opposed to in parallel with the noisy trace.
- Place the external components as close to the device as possible. Keeping RF and RG close to the inverting input minimizes parasitic capacitance, as shown in *Layout Example*.
- Keep the length of input traces as short as possible. Always remember that the input traces are the most sensitive part of the circuit.
- Consider a driven, low-impedance guard ring around the critical traces. A guard ring can significantly reduce leakage currents from nearby traces that are at different potentials.

11.2 Layout Example

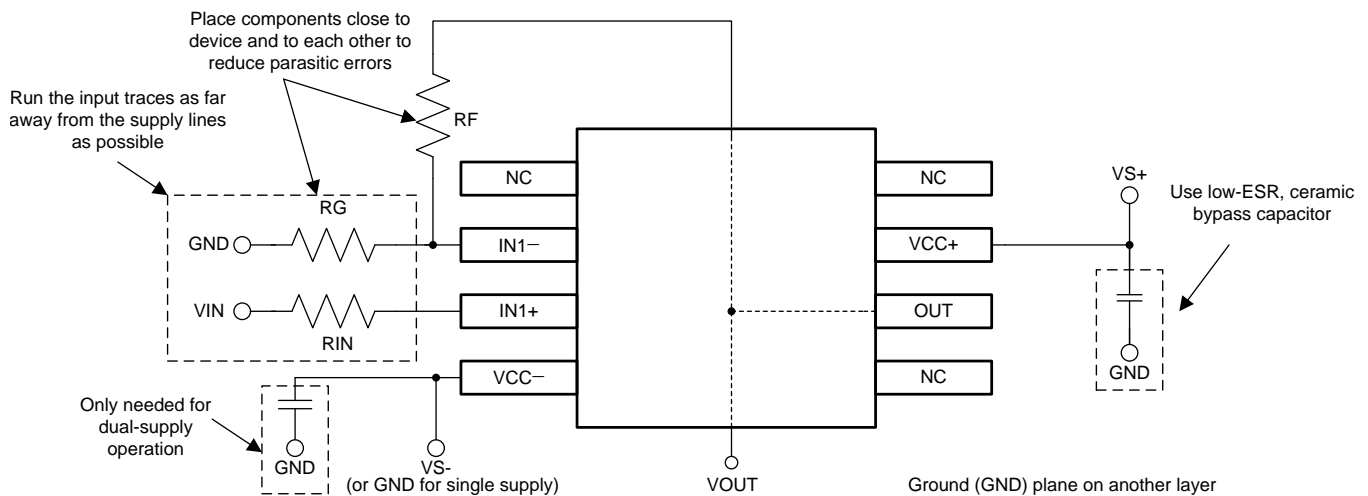

Figure 7. Operational Amplifier Board Layout for Noninverting Configuration

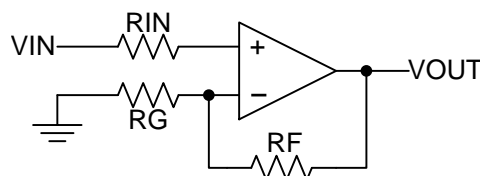

Figure 8. Operational Amplifier Schematic for Noninverting Configuration

12 Device and Documentation Support

12.1 Documentation Support

12.1.1 Related Documentation

For related documentation see *Circuit Board Layout Techniques* ([SLOA089](#)).

12.2 Community Resources

The following links connect to TI community resources. Linked contents are provided "AS IS" by the respective contributors. They do not constitute TI specifications and do not necessarily reflect TI's views; see TI's [Terms of Use](#).

TI E2E™ Online Community *TI's Engineer-to-Engineer (E2E) Community*. Created to foster collaboration among engineers. At [e2e.ti.com](#), you can ask questions, share knowledge, explore ideas and help solve problems with fellow engineers.

Design Support *TI's Design Support* Quickly find helpful E2E forums along with design support tools and contact information for technical support.

12.3 Trademarks

E2E is a trademark of Texas Instruments.
All other trademarks are the property of their respective owners.

12.4 Electrostatic Discharge Caution



These devices have limited built-in ESD protection. The leads should be shorted together or the device placed in conductive foam during storage or handling to prevent electrostatic damage to the MOS gates.

12.5 Glossary

[SLYZ022](#) — *TI Glossary*.

This glossary lists and explains terms, acronyms, and definitions.

13 Mechanical, Packaging, and Orderable Information

The following pages include mechanical, packaging, and orderable information. This information is the most current data available for the designated devices. This data is subject to change without notice and revision of this document. For browser-based versions of this data sheet, refer to the left-hand navigation.

PACKAGING INFORMATION

| Orderable Device | Status (1) | Package Type | Package Drawing | Pins | Package Qty | Eco Plan (2) | Lead finish/ Ball material (6) | MSL Peak Temp (3) | Op Temp (°C) | Device Marking (4/5) | Samples |
|------------------|---------------|--------------|-----------------|------|-------------|-----------------|--------------------------------------|----------------------|--------------|-------------------------|-------------------------|
| LF353DR | ACTIVE | SOIC | D | 8 | 2500 | RoHS & Green | NIPDAU | Level-1-260C-UNLIM | 0 to 70 | LF353 | Samples |
| LF353P | ACTIVE | PDIP | P | 8 | 50 | RoHS & Green | NIPDAU | N / A for Pkg Type | 0 to 70 | LF353P | Samples |
| LF353PE4 | ACTIVE | PDIP | P | 8 | 50 | TBD | Call TI | Call TI | 0 to 70 | | Samples |

(1) The marketing status values are defined as follows:

ACTIVE: Product device recommended for new designs.

LIFEBUY: TI has announced that the device will be discontinued, and a lifetime-buy period is in effect.

NRND: Not recommended for new designs. Device is in production to support existing customers, but TI does not recommend using this part in a new design.

PREVIEW: Device has been announced but is not in production. Samples may or may not be available.

OBSOLETE: TI has discontinued the production of the device.

(2) **RoHS:** TI defines "RoHS" to mean semiconductor products that are compliant with the current EU RoHS requirements for all 10 RoHS substances, including the requirement that RoHS substance do not exceed 0.1% by weight in homogeneous materials. Where designed to be soldered at high temperatures, "RoHS" products are suitable for use in specified lead-free processes. TI may reference these types of products as "Pb-Free".

RoHS Exempt: TI defines "RoHS Exempt" to mean products that contain lead but are compliant with EU RoHS pursuant to a specific EU RoHS exemption.

Green: TI defines "Green" to mean the content of Chlorine (Cl) and Bromine (Br) based flame retardants meet JS709B low halogen requirements of <=1000ppm threshold. Antimony trioxide based flame retardants must also meet the <=1000ppm threshold requirement.

(3) MSL, Peak Temp. - The Moisture Sensitivity Level rating according to the JEDEC industry standard classifications, and peak solder temperature.

(4) There may be additional marking, which relates to the logo, the lot trace code information, or the environmental category on the device.

(5) Multiple Device Markings will be inside parentheses. Only one Device Marking contained in parentheses and separated by a "~" will appear on a device. If a line is indented then it is a continuation of the previous line and the two combined represent the entire Device Marking for that device.

(6) Lead finish/Ball material - Orderable Devices may have multiple material finish options. Finish options are separated by a vertical ruled line. Lead finish/Ball material values may wrap to two lines if the finish value exceeds the maximum column width.

Important Information and Disclaimer:The information provided on this page represents TI's knowledge and belief as of the date that it is provided. TI bases its knowledge and belief on information provided by third parties, and makes no representation or warranty as to the accuracy of such information. Efforts are underway to better integrate information from third parties. TI has taken and continues to take reasonable steps to provide representative and accurate information but may not have conducted destructive testing or chemical analysis on incoming materials and chemicals. TI and TI suppliers consider certain information to be proprietary, and thus CAS numbers and other limited information may not be available for release.

In no event shall TI's liability arising out of such information exceed the total purchase price of the TI part(s) at issue in this document sold by TI to Customer on an annual basis.

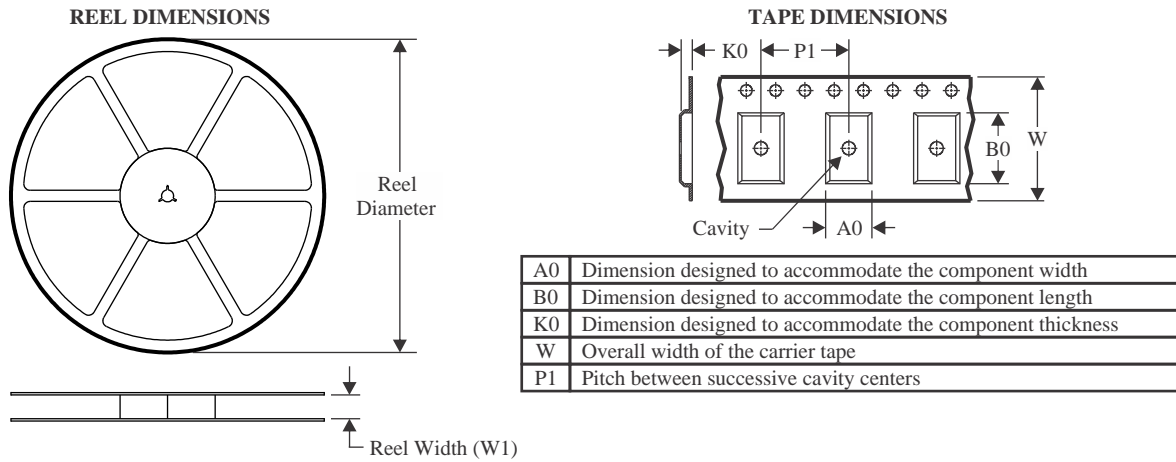
TAPE AND REEL INFORMATION

QUADRANT ASSIGNMENTS FOR PIN 1 ORIENTATION IN TAPE



*All dimensions are nominal

| Device | Package Type | Package Drawing | Pins | SPQ | Reel Diameter (mm) | Reel Width W1 (mm) | A0 (mm) | B0 (mm) | K0 (mm) | P1 (mm) | W (mm) | Pin1 Quadrant |
|---------|--------------|-----------------|------|------|--------------------|--------------------|---------|---------|---------|---------|--------|---------------|
| LF353DR | SOIC | D | 8 | 2500 | 330.0 | 12.4 | 6.4 | 5.2 | 2.1 | 8.0 | 12.0 | Q1 |

TAPE AND REEL BOX DIMENSIONS

*All dimensions are nominal

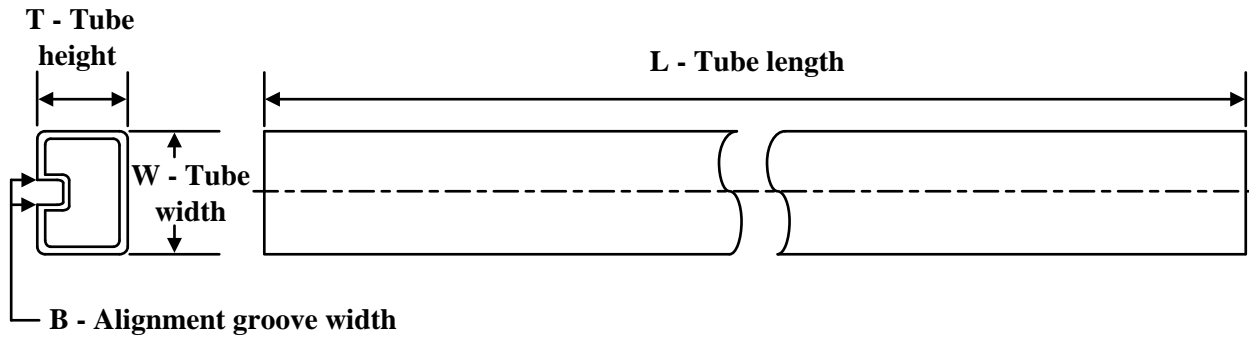
| Device | Package Type | Package Drawing | Pins | SPQ | Length (mm) | Width (mm) | Height (mm) |
|---------|--------------|-----------------|------|------|-------------|------------|-------------|
| LF353DR | SOIC | D | 8 | 2500 | 340.5 | 338.1 | 20.6 |

TUBE

*All dimensions are nominal

| Device | Package Name | Package Type | Pins | SPQ | L (mm) | W (mm) | T (μm) | B (mm) |
|--------|--------------|--------------|------|-----|--------|--------|--------|--------|
| LF353P | P | PDIP | 8 | 50 | 506 | 13.97 | 11230 | 4.32 |



D0008A

PACKAGE OUTLINE

SOIC - 1.75 mm max height

SMALL OUTLINE INTEGRATED CIRCUIT



4214825/C 02/2019

NOTES:

1. Linear dimensions are in inches [millimeters]. Dimensions in parenthesis are for reference only. Controlling dimensions are in inches. Dimensioning and tolerancing per ASME Y14.5M.
2. This drawing is subject to change without notice.
3. This dimension does not include mold flash, protrusions, or gate burrs. Mold flash, protrusions, or gate burrs shall not exceed .006 [0.15] per side.
4. This dimension does not include interlead flash.
5. Reference JEDEC registration MS-012, variation AA.

EXAMPLE BOARD LAYOUT

D0008A

SOIC - 1.75 mm max height

SMALL OUTLINE INTEGRATED CIRCUIT



LAND PATTERN EXAMPLE
 EXPOSED METAL SHOWN
 SCALE:8X



SOLDER MASK DETAILS

4214825/C 02/2019

NOTES: (continued)

- 6. Publication IPC-7351 may have alternate designs.
- 7. Solder mask tolerances between and around signal pads can vary based on board fabrication site.

EXAMPLE STENCIL DESIGN

D0008A

SOIC - 1.75 mm max height

SMALL OUTLINE INTEGRATED CIRCUIT



SOLDER PASTE EXAMPLE
BASED ON .005 INCH [0.125 MM] THICK STENCIL
SCALE:8X

4214825/C 02/2019

NOTES: (continued)

8. Laser cutting apertures with trapezoidal walls and rounded corners may offer better paste release. IPC-7525 may have alternate design recommendations.
9. Board assembly site may have different recommendations for stencil design.

P (R-PDIP-T8)

PLASTIC DUAL-IN-LINE PACKAGE



4040082/E 04/2010

- NOTES:
- A. All linear dimensions are in inches (millimeters).
 - B. This drawing is subject to change without notice.
 - C. Falls within JEDEC MS-001 variation BA.

IMPORTANT NOTICE AND DISCLAIMER

TI PROVIDES TECHNICAL AND RELIABILITY DATA (INCLUDING DATA SHEETS), DESIGN RESOURCES (INCLUDING REFERENCE DESIGNS), APPLICATION OR OTHER DESIGN ADVICE, WEB TOOLS, SAFETY INFORMATION, AND OTHER RESOURCES "AS IS" AND WITH ALL FAULTS, AND DISCLAIMS ALL WARRANTIES, EXPRESS AND IMPLIED, INCLUDING WITHOUT LIMITATION ANY IMPLIED WARRANTIES OF MERCHANTABILITY, FITNESS FOR A PARTICULAR PURPOSE OR NON-INFRINGEMENT OF THIRD PARTY INTELLECTUAL PROPERTY RIGHTS.

These resources are intended for skilled developers designing with TI products. You are solely responsible for (1) selecting the appropriate TI products for your application, (2) designing, validating and testing your application, and (3) ensuring your application meets applicable standards, and any other safety, security, regulatory or other requirements.

These resources are subject to change without notice. TI grants you permission to use these resources only for development of an application that uses the TI products described in the resource. Other reproduction and display of these resources is prohibited. No license is granted to any other TI intellectual property right or to any third party intellectual property right. TI disclaims responsibility for, and you will fully indemnify TI and its representatives against, any claims, damages, costs, losses, and liabilities arising out of your use of these resources.

TI's products are provided subject to [TI's Terms of Sale](#) or other applicable terms available either on [ti.com](https://www.ti.com) or provided in conjunction with such TI products. TI's provision of these resources does not expand or otherwise alter TI's applicable warranties or warranty disclaimers for TI products.

TI objects to and rejects any additional or different terms you may have proposed.

Mailing Address: Texas Instruments, Post Office Box 655303, Dallas, Texas 75265
Copyright © 2023, Texas Instruments Incorporated