

2.8 Watt High Power Edge Light LED Module

Picture:

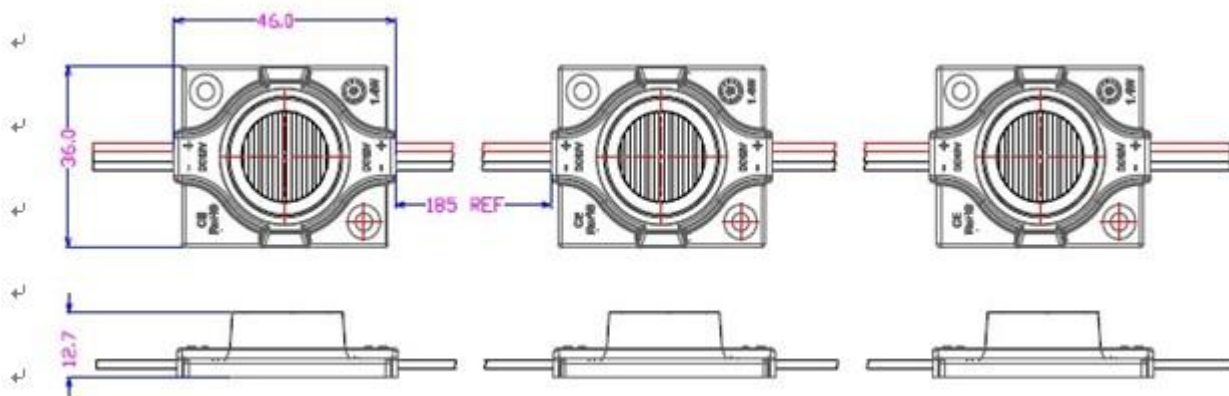

Feature:

1. Best for over 12-25 cm depth Single and Double side Light box.
2. Unique dual angle optical lens design, 56*12 degree, Optimized for use in Double Sided Light box lighting
3. Constant Current drive, 18 pcs per series, Cut off 3 modules.
4. Uniform light effects, No Spot, No shadow area.
5. Easy installation, best for budget solution..
6. CE&ROHS certification, 5 years warranty.
7. Long Span life, 50,000hrs

Specification:

Parameter	Description
Voltage (V)	DC12V
Power (W)	2.8 W/pc
Available Color	Warm White/ Pure White/ Cool White
Color Temperature	3000k/ 6500k/ 9000k
Wave length (nm)	
Lumen	220 Lumen/LED
Viewing angle	56*12 degree
LED Qty	1 led
LED Type	3535 SMD LED
Chip Brand	EPISTAR
Drive Method	Constant Current Drive
Cuttable Unit	3 LED as a Unit can be cuttable
Max Connection	18 pcs per Chain
Dimension	46*36*12.7 mm
IP Rate	IP 67
Cover	Milk White ABS with Optical Lens
Working Temperature	-40°C ~ 60°C
Span life	50,000h
Warranty	3 Years
Certification	CE&ROHS
Part No.	MH-2W

Connection Diagramm

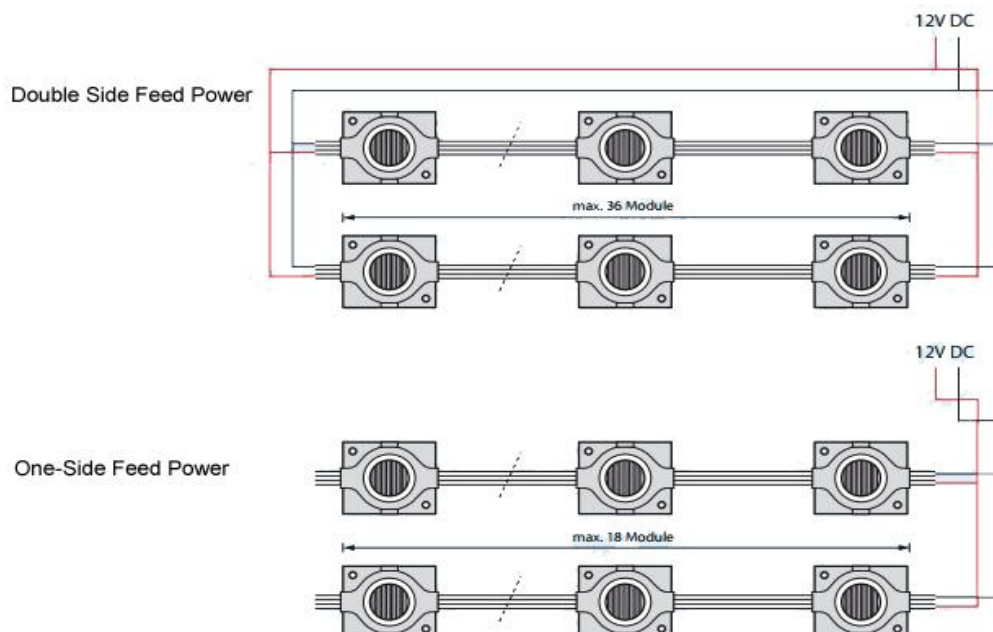

Installation instructions:

1. The thickness of the wires shall be adopted based on the possible current, products power, length of the wire extension (5meter at maximum as recommended) and the loss in the wires transit at low voltage.
2. Module two side wire should do waterproof processed
3. Don't work under the situations of touching in static-electronics environments or light on.
4. The modules can be serials connect 18pcs at maximum and no exceed;
5. Suggest choosing high- quality switch power (have short electronics ,overvoltage and overloading protection function etc)

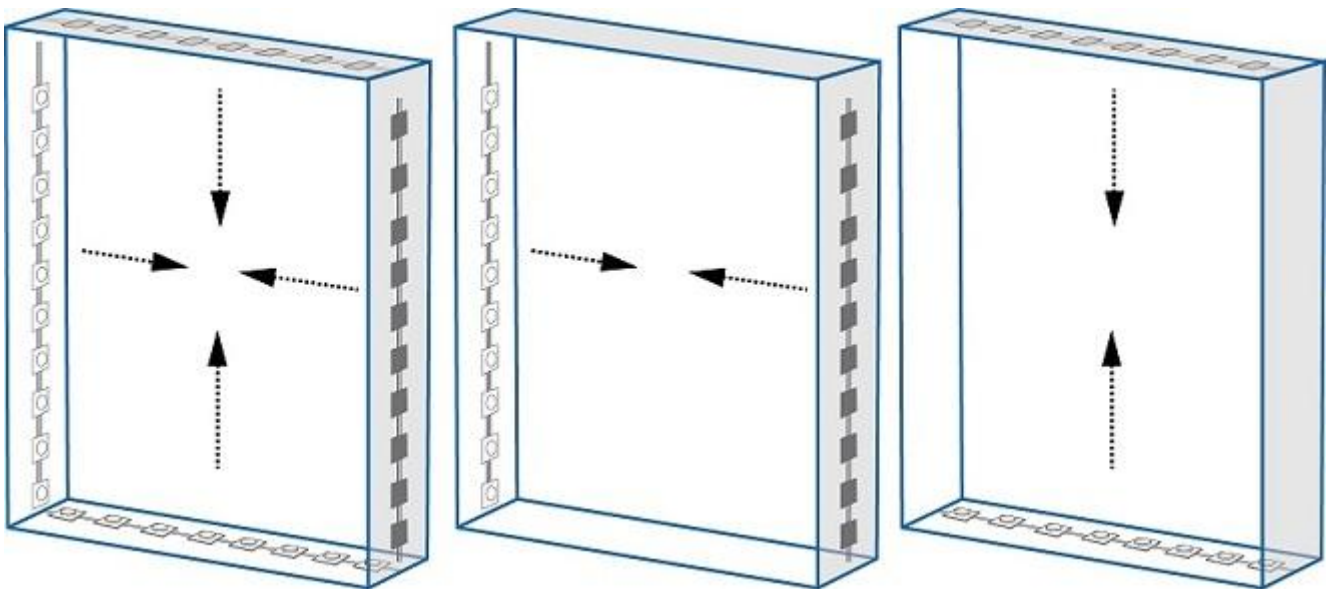
**Application:**

1. Best for 12-25cm depth Double side Lighting box
2. Illuminated for big size led glow sign board.