

1.4 Watt Small Size Edge Light LED Module

Picture:

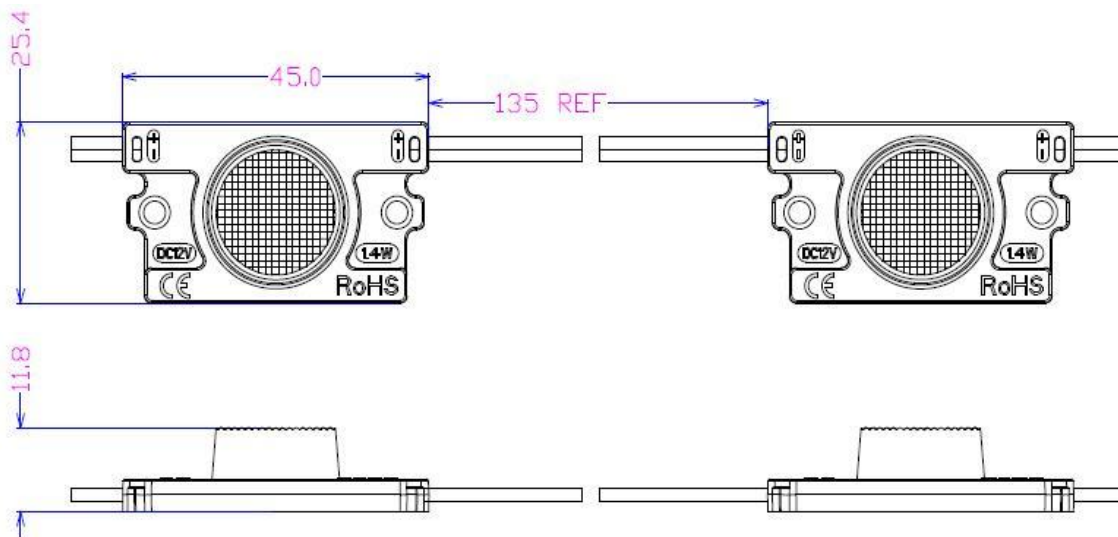

Feature:

1. Best for over 10-20 cm depth Single and Double side Light box.
2. Unique dual angle optical lens design, 15*45 degree, Optimized for use in Double Sided Light box lighting
3. Use EMC light source, low lumens depreciation, fast heat dissipation, high efficiency.
4. PCB aluminum plate with high quality aluminum, good heat sinking and long lifespan.
5. Ensure the product stable performance, long life, good brightness uniformity.
6. CE&ROHS certification, 3 years warranty.

Specification:

Parameter	Description
Voltage (V)	DC12V
Power (W)	1.4 W/pc
Available Color	Warm White/ Pure White/ Cool White
Color Temperature Wave length (nm)	2700-3300k/6000-6500k/ 9000-12000k
Lumen	120-130lm
Viewing angle	15*45° degree
LED Qty	1 led
LED Type	EMC 2835 or 3030 SMD LED
Chip Brand	Epistar Chip
Drive Method	Constant Current Drive
Cutttable Unit	1 LED as a Unit can be cuttable
Max Connection	30 pcs per Chain
Dimension	45*26*11.8 mm
IP Rate	IP 67
Cover	Milk White ABS with Optical Lens
Working Temperature	-25°C ~ 60°C
Span life	50,000h
Certification	CE&ROHS
Part No.	MH-1WB

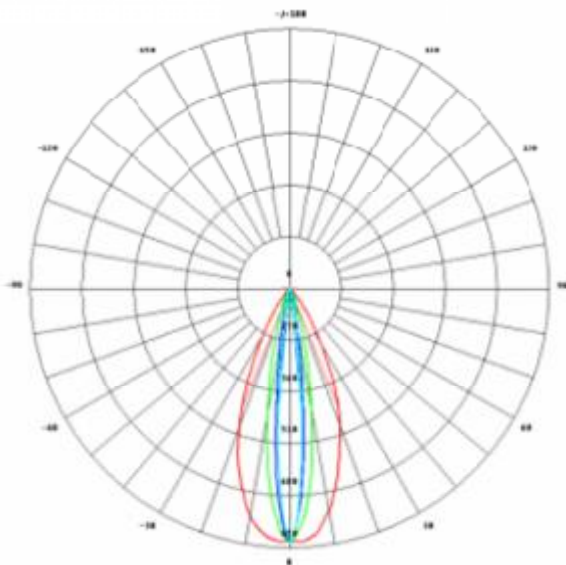
Light Distribution Curve:

Installation instructions:

Installed on the box bottom, back glue scheduled, fixed with screw.

Cascade can cut, 1pcs modules can be cut.

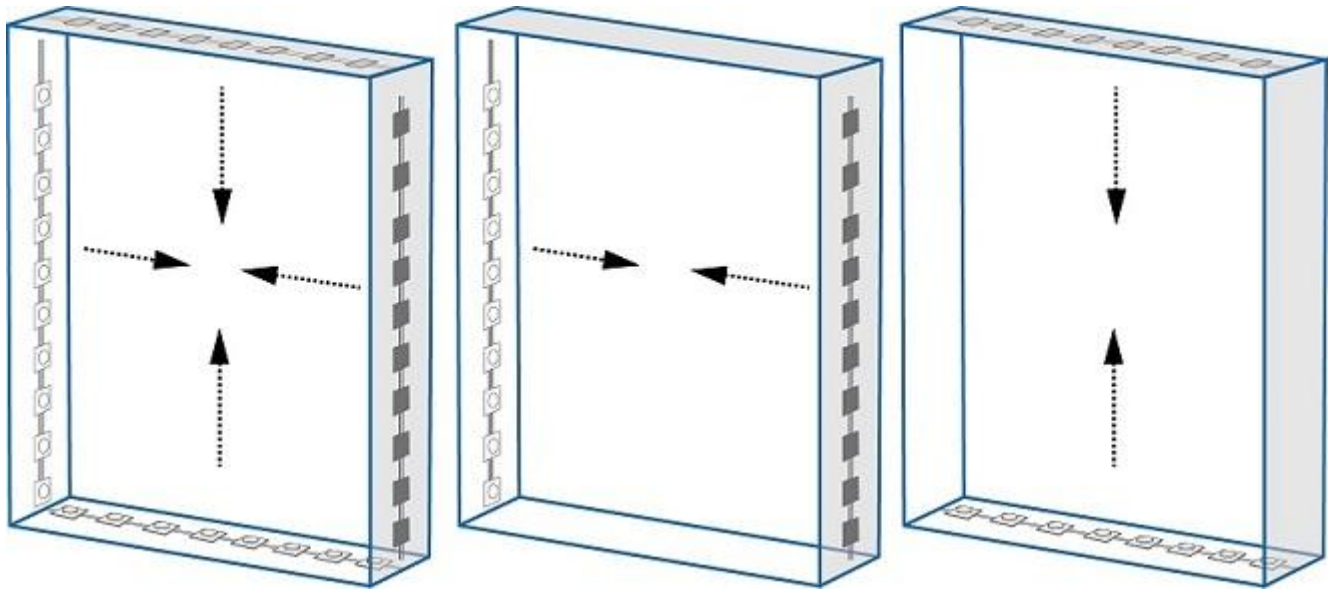
**Application:**

1. Best for 10-20cm thickness of light box
2. Shopping malls, airport, subway, bus station and other places of light box