

M12 Cable Assemblies and Circular Series Connectors (CSC)

Application Specification
114-137144
 05 JAN 2023 REV. A8



NOTE

All numerical values are in metric units [with U.S. customary units in brackets]. Dimensions are in millimeters. Unless otherwise specified, dimensions have a tolerance of ± 0.13 and angles have a tolerance of $\pm 2^\circ$. Figures and illustrations are for identification only and are not drawn to scale.

1. INTRODUCTION

This specification covers the requirements for application M12 cable assemblies and CSCs for printed circuit (pc) board and panel mounting applications. The cable assembly and connectors are designed for use in industrial equipment and control, signal, and electrical appliances. The plugged cable assembly and connectors have an ingress protection rating of IP67.

The connectors are available as field installable with screw termination and panel mount available with wires or solder type through-hole pc board mount contacts. The connectors consist of a female (receptacle) and a male (plug) and are available in unshielded or shielded and straight or angled. The cable assembly is available in single ended and double ended with straight and angle connectors. When corresponding with personnel, use the terminology provided in this specification to facilitate inquiries for information. Basic terms and features of this product are provided in Figure 1.

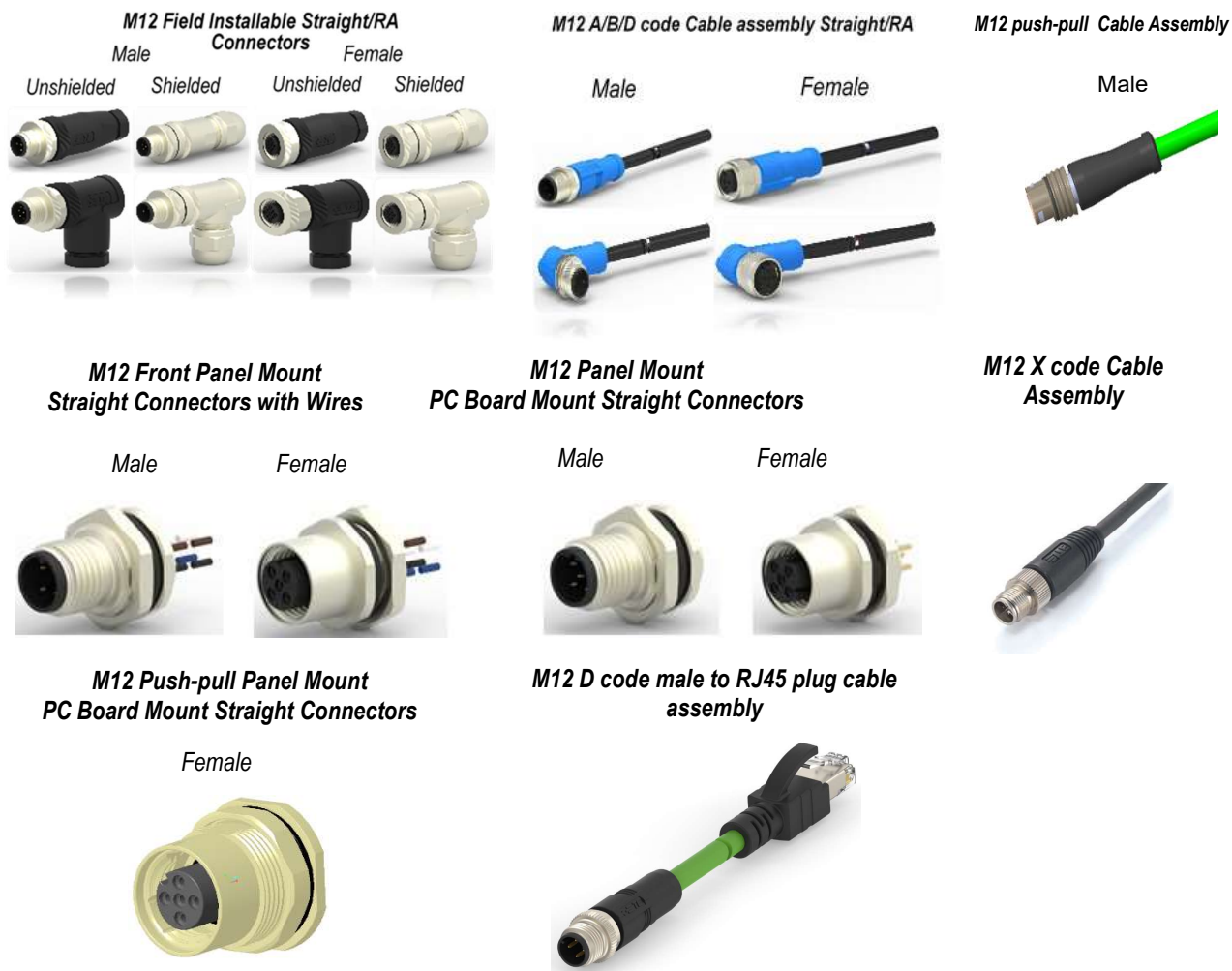

Figure 1

2. REFERENCE MATERIAL

2.1. Revision Summary

Initial release of application specification

2.2. Customer Assistance

Reference Product Base Part Numbers

T411XXXXXXXX-XXX (M12 field installable connector) and

T413XXXXXXXX-XXX (M12 panel mount sold type connector) and

T414XXXXXXXX-XXX (M12 panel mount PCB solder type connector) and

T417XXXXXXXX-XXX (M12 panel mount connector with wire) and

T415XXXXXXXX-XXX (M12 cable assembly, un-shielded type) and

T416XXXXXXXX-XXX (M12 cable assembly, shielded type)

TAAXXXXXXXXX-XXX, TABXXXXXXXX-XXX (M12 cable assembly for field bus applications)

TADXXXXXXXX-XXX ,

RPC-M12X-8MS-xxxxxSH-RJ45-8MS-TPE

RPC-M12D-4MS-xxxxxSH-M12D-4FS-TPE

RPC-M12D-4MS-xxxxxSH-RJ45-4MS-TPE

RPC-RJ45-8MS-xxxxxSH-RJ45-8MS-TPE

RPC-M12X-8FS-xxxxxSH-RJ45-8MS-TPE

RPC-M12D-4FS-xxxxxSH-RJ45-4MS-TPE

(M12 X code & D code & RJ45 cable assembly industrial ethernet applications)

TCDXXXXXXXX-XXX (M12 D code to RJ45 plug cable assembly industrial ethernet application)

Use of these numbers will identify the product line and help you to obtain product and tooling information. Such information can be obtained through a local Representative, by visiting our website at www.te.com, or by calling PRODUCT INFORMATION or the TOOLING ASSISTANCE CENTER at the numbers at the bottom of page 1.

2.3. Drawings

Customer Drawings for product part numbers are available from the service network. If there is a conflict between the information contained in the Customer Drawings and this specification or with any other technical documentation supplied, the information contained in the Customer Drawings takes priority.

2.4. Specifications

Product Specification 108-106140 provides product performance and test requirements.

Product Specification 108-137541(M12 D code to RJ45 plug) provides performance and test requirements

Product Specification 108-137420(M12 push-pull type) provides product performance and test requirements

2.5. Instructional Material

Instruction Sheets (408-series) provide product assembly instructions.

2.6. Standards and Publications

Standards and publications developed by the International Electrotechnical Commission (IEC) provide industry test and performance requirements. Standards available that pertain to this product are:

IEC 61076-2-101, "Connectors for Electronic Equipment—Product Requirements—Part 2-101: Circular Connectors—Detail Specification for M12 Connectors with Screw Locking"

IEC 61076-2-104, "Connectors for Electronic Equipment—Product Requirements—Part 2-104: Circular Connectors—Detail Specification for Circular Connectors with M8 Screw Locking or Snap Locking"

IEC 61076-2-109, "Connectors for Electronic Equipment—Product Requirements—Part 2-109: Circular Connectors—Detail Specification for Connectors with M12*1 Screw Locking for Data Transmission Frequencies Up to 500 MHz"

IEC 61076-2-012 " Connectors for electrical and electronic equipment – Product Requirements – Part 2-012: Circular connectors – Detail specification for connectors with inner push-pull locking based on M12 connector interfaces according to IEC 61076-2-101, IEC 61076-2-109, IEC 61076-2-111 and IEC 61076-2-113"

IEC60603-7 "Connectors for electronic equipment-Part 7: Detail specification for 8-way, unshielded, free and fixed connectors"

IEC60603-7-3 "Connectors for electronic equipment-Part 7-3: Detail specification for 8-way,shielded,free and fixed connectors, for data transmission with frequencies up to 100 MHz

2.7. Manuals

Manual [402-40](#) can be used as a guide to soldering. This manual provides information on various flux types and characteristics with the commercial designation, flux removal procedures, and a guide for information on soldering problems.

3. REQUIREMENTS

3.1. Storage

A. Ultraviolet Light

Prolonged exposure to ultraviolet light may deteriorate the chemical composition used in the product material.

B. Shelf Life

The product should remain in the shipping containers until ready for use to prevent deformation to components. The product should be used on a first in, first out basis to avoid storage contamination that could adversely affect performance.

C. Chemical Exposure

Do not store product near any chemical listed below as they may cause stress corrosion cracking in the material.

Alkalies	Ammonia	Citrates	Phosphates	Citrates	Sulfur Compounds
Amines	Carbonates	Nitrites	Sulfur Nitrites		Tartrates

3.2. Operating Temperature

The cable assemblies and connectors must be used within the operating temperature given on the customer drawing for the specific connector.

3.3. Cable Selection

The connectors accept cable having the requirements given on the specific connector customer drawing. In this specification, when the connector assembly procedure depends on the cable shield outer diameter, that diameter is included in the assembly requirements of Paragraph 3.4.

3.4. M12 Cable Preparation and Connector Assembly

A. M12 Field Installable Connectors (T411)

These connectors must meet the cable preparation and connector assembly requirements given in Figure 2 and Figure 3.

B. Cable Assembly (T415/6,TAA,TAB,TAD,TCD)

Cable assembly have code indicator for easily assembly as shown in customer drawing.

The cable of the cable assembly must remain perpendicular to the connector and avoid an excessively sharp bend radius and loading. The minimum bend radius of a cable is $\pm 10^\circ$.



Must not unlock and un-screw the male(plug) nut rudly, which will be get stuck due to special structure design.

Tips: At the same time of un-screw, a bit pull out force will help unlock easily.

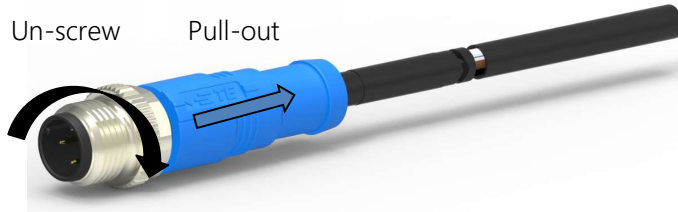

M12 Field Installable Connector

Unshielded Cable
3-12-Position Connectors
Straight Connector

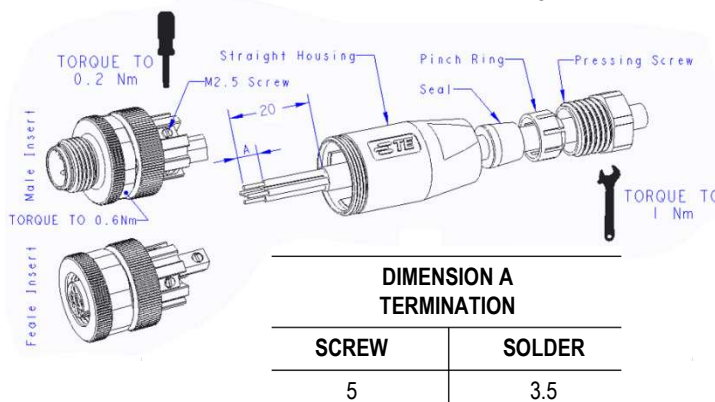

1. Connector components install on cable
2. Cable jacket should be stripped as shown
3. For 3-8-position, install wire to correct insert position (wire plug should be preferred to crimp on the wire)
4. Turn the M2.5 screw with suitable tool, torque to 0.2Nm [1.77 in.-lb.]
For 12-position, sold the wire
5. Install straight housing
6. Install seal, pinch ring, pressing screw
7. Pressing screw should be tightened with torque recommended as 1 Nm [8.85 in.-lb.]
8. Cable outlet: PG7 (cable feed: 4-6mm)
PG9 (cable feed: 6-8mm)

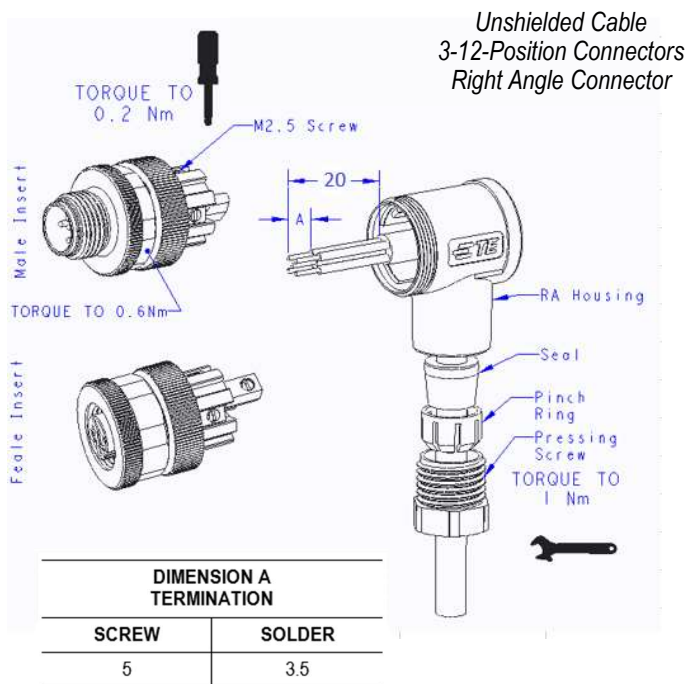

1. Connector components install on cable
2. Cable jacket should be stripped as shown.
3. For 3-8-position, install wire to correct insert position (wire plug should be preferred to crimp on the wire)
4. Turn the M2.5 screw with suitable tool, torque to 0.2Nm [1.77 in.-lb.]
For 12-position, sold the wire
5. Install straight housing
6. Install seal, pinch ring, pressing screw
7. Pressing screw should be tightened with torque recommended as 1 Nm [8.85 in.-lb.]
8. Cable outlet: PG7 (cable feed: 4-6mm)
PG9 (cable feed: 6-8mm)

Figure 2 (End)

M12 Field Installable Connector Shield type

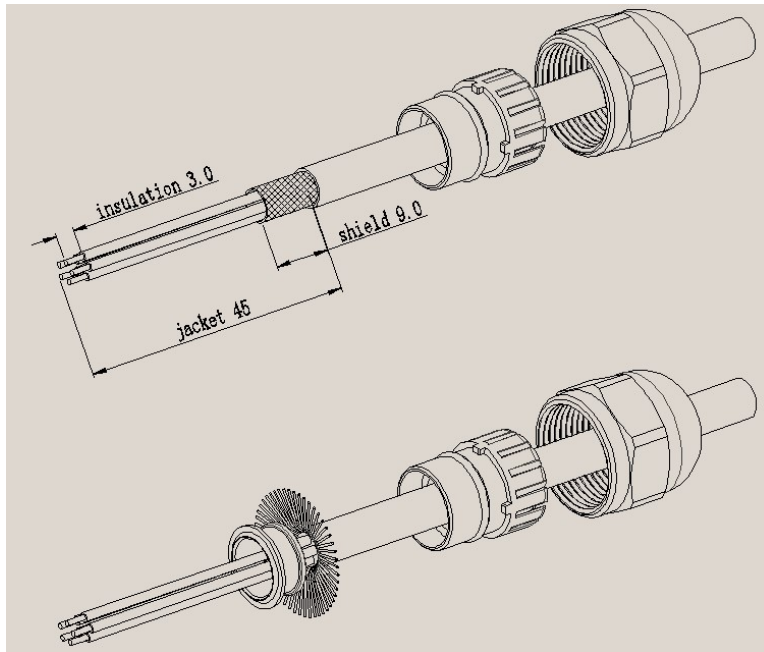

1. Connector components must be installed on cable.
2. Cable jacket must be stripped.
3. Housing, shielding ring, sealing ring, and pinch ring must be installed over individual wires and onto cable.
4. Pressing screw must be tightened: torque of 1 Nm [8.85 in.-lb]
5. For right-angle connector, locking screw must be tightened.
6. Cable outlet:
 - PG7 (cable feed: 4-6mm)
 - PG9 (cable feed: 6-8mm)
 - PG11&PG9 XL PB(cable feed:8-10mm)

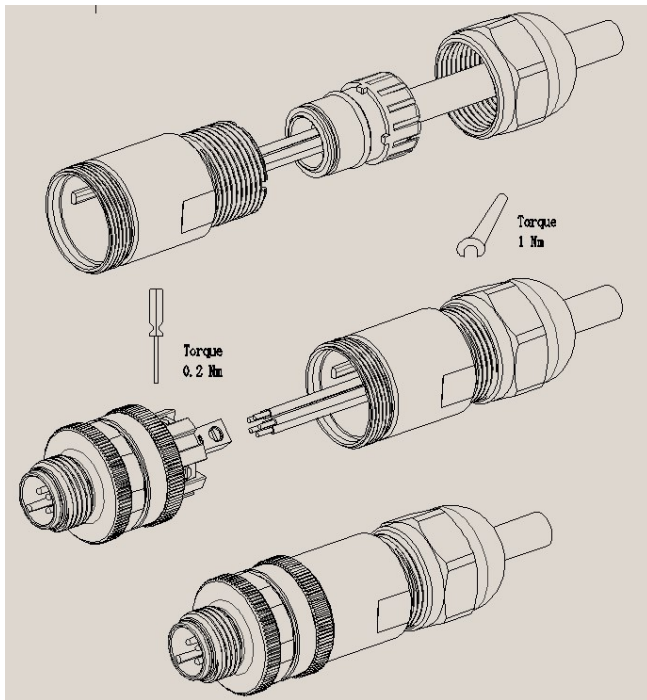

Straight

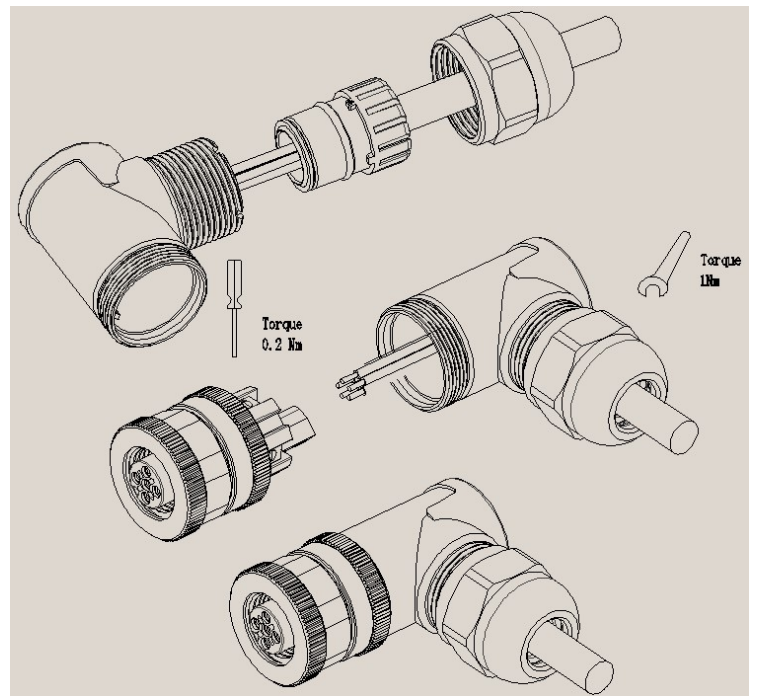

Right angle

Figure 3(a) PG7/PG9 TYPE

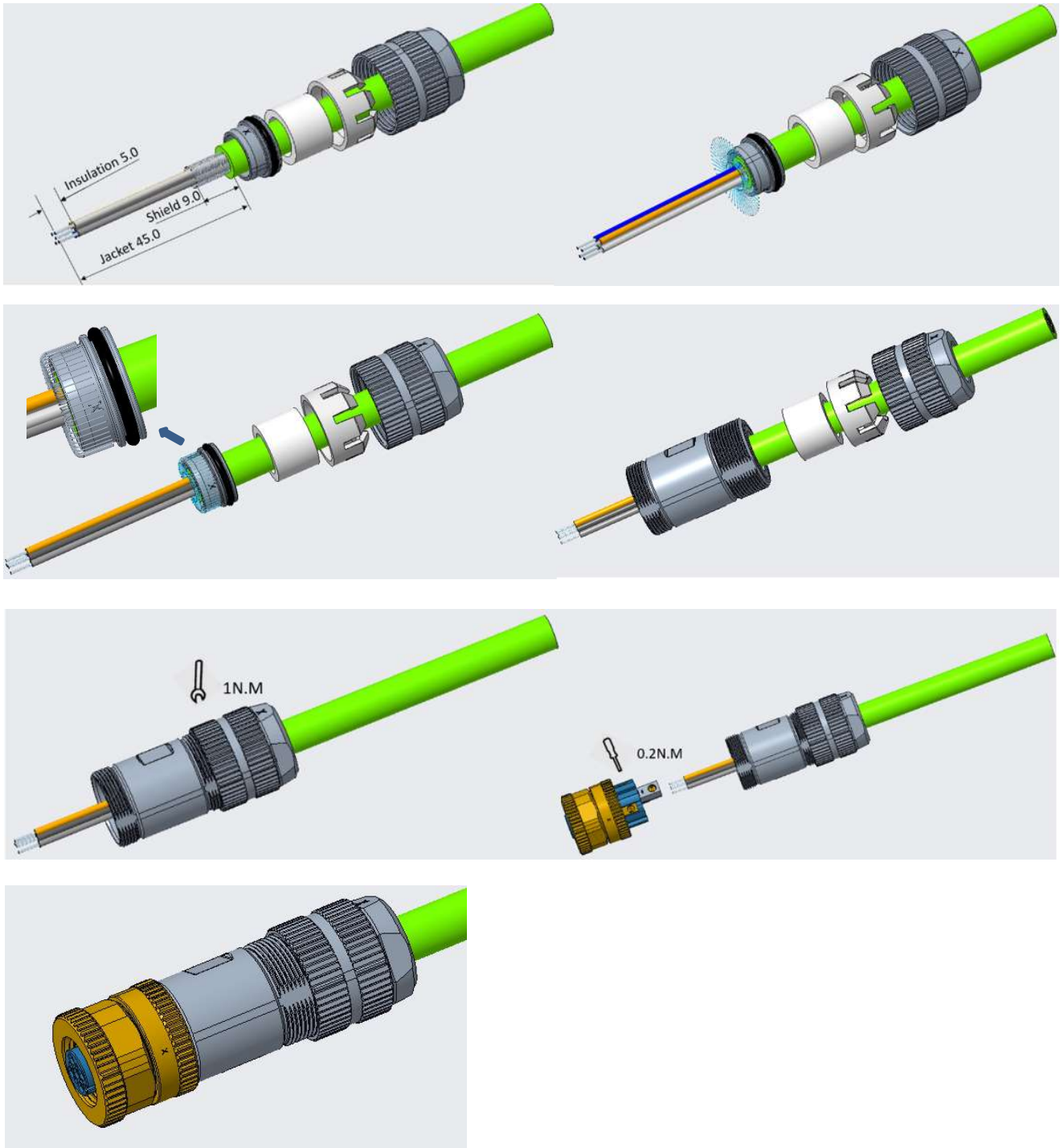

Figure 3(b) PG11 & PG9 XL PB STRAIGHT TYPE

3.5. Panel

3.5.1 Non-push-pull type

3.5.1.1 Recommended Thickness and Cutout refer to customer drawing

The panel thickness shall be Max. 4.0mm for female rear panel mount (Alternatively: The panel thickness shall be 2.5 - 4.0mm with anti-rotation protection), (PNS: T413XXXXXXXX-000, T414XXXXXXXX-000, T417XXXXXXXX-00X). other types 2.5mm.

The panel thickness shall be Max. 4.5mm for male and female rear panel mount (Alternatively: The panel thickness shall be 2.5 - 4.5mm with anti-rotation protection), (PNS: T413XXXXXXXX-001, T414XXXXXXXX-001, T417XXXXXXXX-80X).

The recommended panel cutouts are given in Figure 4.

Recommended Panel Cutout for M12 Connectors

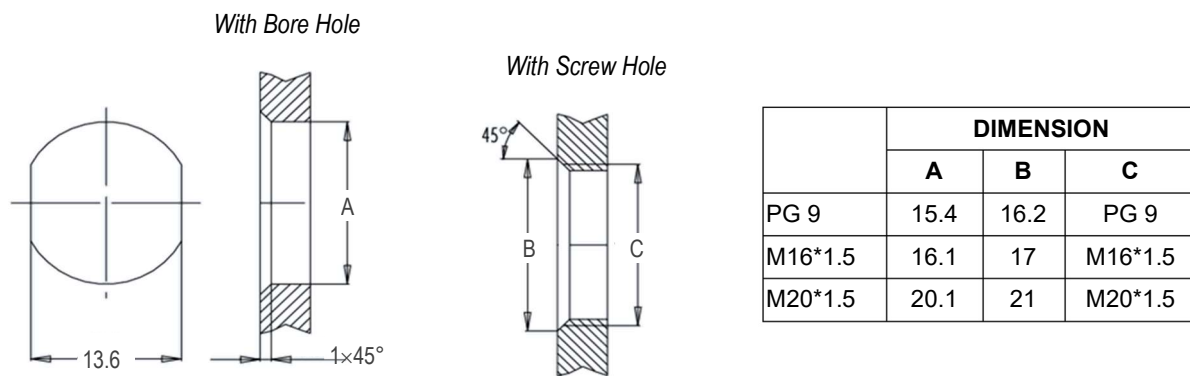

Figure 4

3.5.1.1 There are two rotational orientations for mounting the connector to the panel: top/bottom and left/right. This orientation must be chosen before creating the cutout in the panel. Figure 4

3.5.1.2 Mounting

The connector is designed to be front or rear panel mounted. The mounted connector must meet the following requirements:

- the flat of the connector must be aligned with the flat edge cut in the panel
- the O-ring must be between the flange and the panel, beside the panel chamfer side
- the gasket must be flat against the panel
- the panel nut must be flat against the panel and tight to the torque given in Figure 5

SCREW TYPE	TORQUE (Nm [lb-ft])
	Metal Housing
M12*1, PG9, M16*1.5, M20*1.5	1.0 [0.74]

Figure 5

3.5.2 M12 Push-pull type

3.5.2.1 Recommended Thickness and Cutout refer to customer drawing

The panel thickness shall be Max. 4.5mm for female rear panel mount, the recommended panel cutouts are given in Figure 6.

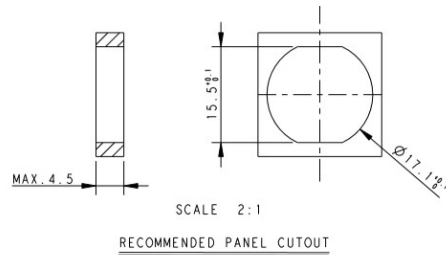

Figure 6

3.5.2.2 Recommended thickness and cutout for M12 push-pull panel mount connector, it refers to customer drawing

The connector is designed to be front or rear panel mounted. The mounted connector must meet the following requirements:

- the flat of the connector must be aligned with the flat edge cut in the panel
- the O-ring must be between the flange and the panel
- the gasket must be flat against the panel
- the panel nut must be flat against the panel and tight to the torque with 1.0Nm

3.5.2.3 Warning label

Stick the warning label (Figure 7) to panel and around connector, it can provide warning information for 'Not for current interrupting'. Figure 8



Figure 7

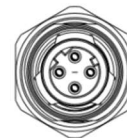

Figure 8

3.6 Mating and Un-mating



DANGER

To avoid personal injury, these connectors and cable assemblies must not be mated or unmated under live conditions (electrical load).

Pour éviter des dommages corporels, ces connecteurs et assemblages de câbles ne doivent pas être accouplés ou non accouplés sous tension (charge électrique).

3.6.1 The recommended torque for mating the connectors is:

M12 connectors: 0.6 Nm [0.44 lb-ft]

3.6.2 M12 Push-pull type mating

3.6.2.1 Align insert mark, Figure 9

3.6.2.2 Insert the plug till the click, Figure 10

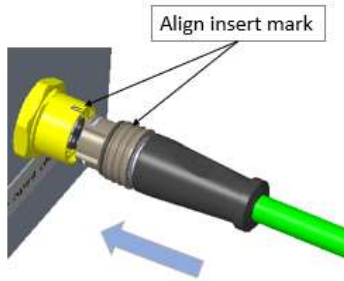

Figure 9

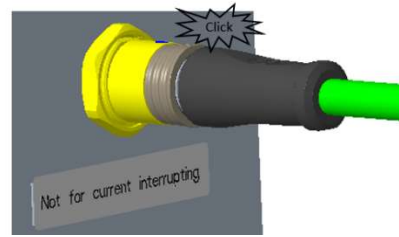

Figure 10

3.6.3 M12 Push-pull un-mating

Grab the handle, and pull out the handle ring, then M12 push-pull plug will pull out. Figure 11

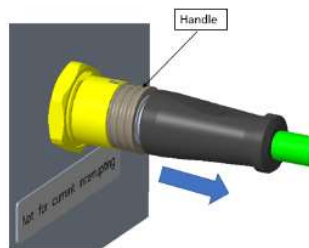

Figure 11

3.6.4 M12 Push-pull female connector mate with M12 metric male plug, Figure 12

M12 Push-pull female receptacle can both adopt M12 push-pull male plug and metric male plug. The mating process is same as M12 metric product.

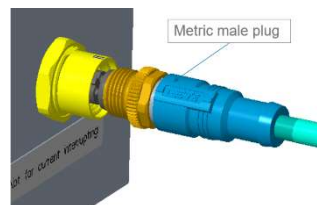

Figure 12

3.7 Replacement and Repair

These cable assemblies and connectors are not repairable. Damaged or defective components must not be used. Connectors must not be re-used by removing the cable.

Fitting and servicing should only be performed by qualified personnel in accordance with all guidelines and standards.

4 QUALIFICATION

M12 cable assemblies are recognized by Underwriters Laboratories Inc. (UL)

5. TOOLING

No tooling is required for assembly of M12 cable assemblies and CSC.